

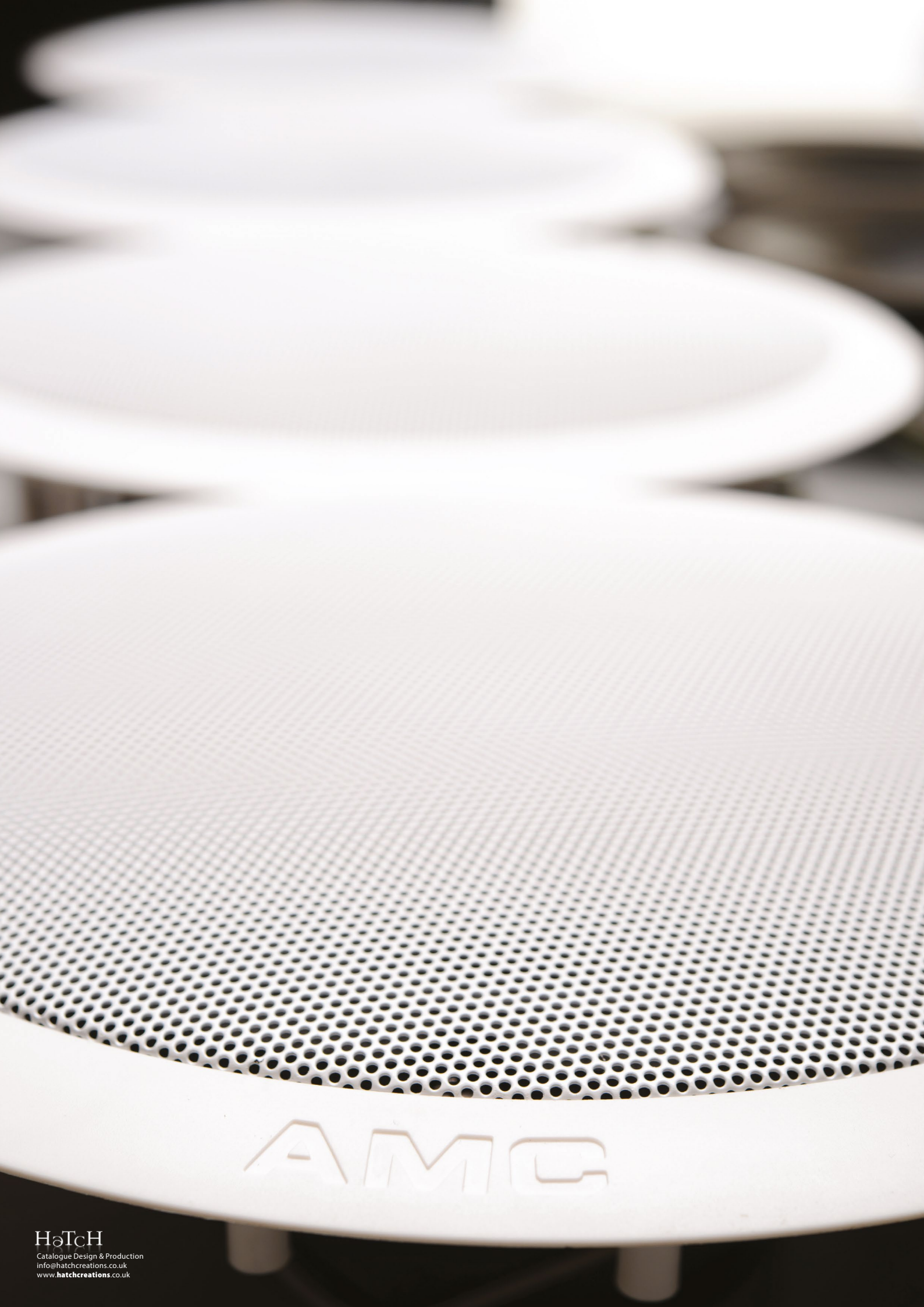

Product Catalogue

Simple. Reliable. Profitable.



AMG

HəTcH

Catalogue Design & Production
info@hatchcreations.co.uk
www.hatchcreations.co.uk

An Introduction to AMC Baltic

Wherever you go, whatever public facility you visit,
a good, reliable sound system is essential.

OUR CREDO

With over 10 years of experience, AMC Baltic® provides the best possible solutions and redefines the benchmark for affordable commercial sound equipment. Specializing in Public Address and other commercial audio applications, the AMC product range covers the needs of even the most demanding of users and applications.

Simplicity

All of our products are easy to install and use. Because of the flexibility of our housings, loudspeakers can be quickly and easily installed into ceilings or walls. Many of our devices (such as loudspeakers, amplifiers and preamplifiers) use Phoenix connectors which makes it easy to connect our equipment, without any special tools and this saves on installation time. Our products blend into a wide variety of contemporary interiors and become an integral part of the architecture. For simplicity, the main controls of the electronic equipment are located in the front panel and are marked by clearly understandable symbols, while the control elements for professional use are located in the rear. We help installers by printing the main technical parameters on the product box and label, making selection and installation easier and avoids mistakes. Our professional audio music players will play files from USB flash and SD memory media.

Reliability

Our products will give consistently great results, even if used 24/7. Simplicity of design, using only premium suppliers for our minimum moving part components, gives our product range the edge in reliability. Loudspeaker enclosures are produced from high quality ABS plastic. Amplifiers and players are extremely resistant to dust and high temperatures and overload protection circuits are built into almost every device. All of this, combined with a rarely called-upon guarantee, gives the consumer total peace of mind. Our 10 years experience of providing professional engineering solutions enables us to deliver the most reliable devices to the audio industry. Our products are equally comfortable inside or outside a building; they are capable of being driven hard anywhere. We know this because we constantly test them in the lab and in the real world.

Profitability

We are able to maintain an exceptional price-to-quality ratio by selling in large quantities, thus enabling our costs to be more competitive when compared to our rivals. Because of this sales structure, together with a fantastic product range that offers a complete solution, we are more attractive to big installation and construction companies. Ultimately, we save our customers money. For the dynamically developing audio market AMC Baltic is able to offer a continuously updated portfolio of products, which provides an advantage to our distributors in the competitive marketplace.

Whilst every effort has been made to ensure that the information in this catalogue is correct, we accept no liability in respect of errors or omissions. All specifications within the AMC Product Catalogue are subject to change as products are updated.





ABOUT US

AMC Baltic started in January 2008, as a manufacturer of loudspeakers and electronics.

Since 2000, AMC had been known as a leading brand in the audio industry. It is a modern and flexible company, operating in this highly competitive international market. Our prime target is the contractor market. We provide reliable, high quality, simple and competitively priced products, and our main focus is on the public address and voice evacuation markets. These markets

demand big quantities and a fast delivery times. You can order thousands of loudspeakers from us and they will usually be in stock; immediate shipment means they reach our customers soon after. Today we sell to 30 countries worldwide, and you can see our products with the AMC logo in many prestigious buildings around the globe.

AMC Worldwide

AMC products are recognizable in many prestigious buildings around the globe.

Case Studies & Environments

We sell to 30 countries worldwide. Some of our customers are:

Abas, Audiologic, Audio Integrate, Audiovision, AVB, AVDis, AVR, BLC Turva, CSL Project, Eltek, ESistemas, Genaudio, GVI Vertriebs, Honeywell, Ignite Technologies, Imlight Showtechnic, Josawa Trading Enterprise, Karadag Elektronic, Lightek, Mediaspro, Megasound, Megavoice, Novar, Phono Media, Proeling, Promedias, Prostage, Sisme, Sound Productions Limited, Smart Audio, Sta Techniks, V.V & Sons, Zoom Tech Electronics



Hilton Garden Inn

Unified complex of buildings, with high-requirements sound system, located in the center of Vilnius, Lithuania.



Xanadu Resort Hotel

Luxurious resort on the shore of Mediterranean sea. Located in Antalya, Turkey



Zalgiris Arena

The largest 15.000 capacity Sport and Entertainment arena in the Baltic states, located in Kaunas, Lithuania.



THE BILKENT INTEGRATED HEALTHCARE CAMPUS

Europe's biggest hospital complex in Turkish capital Ankara



Thessaloniki Airport

The third-largest international airport in Greece, serving Thessaloniki



Hotel Central

Newly renovated hotel in excellent location in old city of Bucharest, Romania.



Hotel Central

Newly renovated hotel in excellent location in old city of Bucharest, Romania.



Veli Vrh

The modern new primary school in Pula, Istria, Croatia.



Casa Garcalian Resto Bar

Leisure place at Balayan bay shore, San Luis Batangas.



"Let'Z meet" Restaurant

"Let'Z meet" – new attraction place for food lovers in Netherlands.

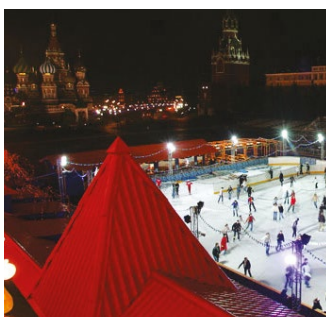

Skating Rink

The king of all outdoor rinks! The ice rink covers more than 3000m² and is located in the heart of Moscow in Red Square.



Europea

The most sophisticated retail, residential, office and leisure center in Central Europe, Bratislava, Slovakia.

Our products are used across many sectors in a variety of architectural environments.

Houses of Worship

Churches, Mosques, Temples, Cathedrals and Synagogue's

Transportation Hubs

Airports, Ferry Ports, Train and Bus Terminals

Public Galleries

Museums, Aquariums, Art and Exhibition Centres

Halls of Education

Libraries, Schools, Colleges and University Campus

Retail

Outlets, Supermarkets and Shopping Centers

Food & Drink Establishments

Cafés, Pubs, Bars, Coffee Houses and Restaurants

Corporate AV

Factories, Offices, Boardrooms and Conference Facilities

Public Accomodation

Hotels, Motels, Inns and Boarding Houses

Sporting & Leisure

Stadiums, Arenas, Gyms, Rinks, Pools & Sport Centres

Entertainment

Music Venues, Theaters, Cinemas and Auditoria

Health & Beauty Insitutes

Surgeries, Hospitals, Medical Centres and Spa's

Manufacturing, Testing & Distribution

AMC products are recognizable in many prestigious building

OUR PRODUCTS

We design and produce products dedicated to the public address and voice evacuation markets. Millions of loudspeakers and thousands of electronic devices with the AMC logo are installed in locations all around the World. Their function enables voices and music to be heard clear and pure, without creating an unpleasant or invasive audio environment.



Quality of Build

We use only the highest quality components we have selected for inclusion in our build process, since we consider this to be of the greatest importance to the product, and the end user. We control and monitor assembly of the product at every stage and use high quality tools and hardware in the process.



Quality Control

From sourcing of the raw materials to manufacture of the final products, we take special care about the product control. The materials we use in our electronic units are subject to the most stringent requirements in terms of both specification and quality. We ensure that components are ROHS compliant. Throughout the production process we examine and test the quality of our products. Then, the product is finally tested and examined through our high-spec laboratories.

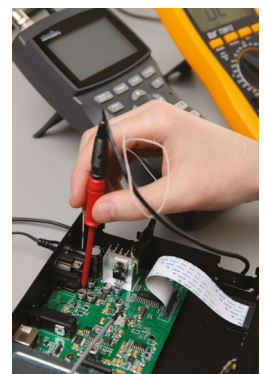

Stock Control

It is most important for us that the product will be in stock, the last stage before reaching the buyer. We control incoming product quality and ensure the best storage conditions and quantity control. Our products are kept safely in a modern warehouse, where the process of paperwork and collecting the shipments is automated using a bar code control system.

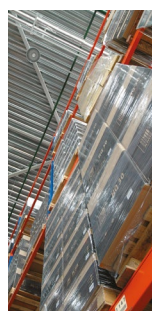

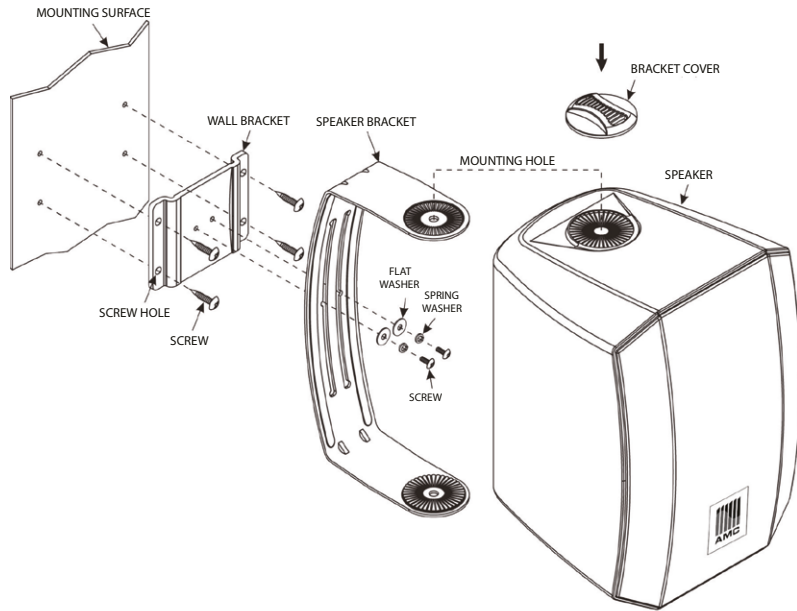

Instillation

During the product development and production we always consider the installers, those who will affix and commission our products on site. We always ensure that our products are user-friendly and easy to install.



Our Range

We have a very wide range of the products across two main lines. Loudspeakers: ceiling, wall mount, horn speakers, sound projectors and spherical speakers. Electronics: preamplifiers, players, amplifiers, wireless and wired microphones.







LOUDSPEAKER INDEX

EN54-24 CERTIFIED VOICE EVACUATION LOUDSPEAKERS

MC 4EN Voice Evacuation Metal Ceiling Loudspeakers	13
iSpeak 5EN Voice Evacuation Surface Mount Plastic Loudspeakers	14
SP 10EN Voice Evacuation Plastic Sound Projectors	15
HQ 10EN Voice Evacuation Plastic Horn Loudspeakers	16
HQ 15EN Voice Evacuation Plastic Horn Loudspeakers	17

CABINET LOUDSPEAKERS

iPlay 4T, 5T & 6 Wall Mount Plastic Loudspeakers.....	18-19
iSpeak 5 / iSpeak 5R Surface Mount Plastic Loudspeakers	20-21
iSpeak 6 Surface Mount Plastic Loudspeakers.....	22
PS 6 Surface Mount Plastic Loudspeakers	23
EVACW 5 Surface Mount Metal Voice Evacuation Loudspeakers	24
W3 & W10 Wall Mount Plastic Loudspeakers	25
VIVA 3 Wall Mount Plastic Loudspeakers.....	26
VIVA 4 Wall Mount Plastic Loudspeakers.....	27
VIVA 4IP Outdoors Wall Mount Plastic Loudspeakers.....	28
VIVA 5 Wall Mount Plastic Loudspeakers.....	29
VIVA 8 Wall Mount Plastic Loudspeakers.....	30
VIVA 3-302T Wall Mount Plastic Loudspeakers	31

METAL CEILING LOUDSPEAKERS

MC 4TA Metal Ceiling Loudspeakers	32
MC 6T Metal Ceiling Loudspeakers	33
EVAC 50X Voice Evacuation Metal Ceiling Loudspeakers	34

LOW IMPEDANCE CEILING LOUDSPEAKERS

PC 6 Low Impedance Ceiling Loudspeakers	35
PC 6HP Low Impedance Ceiling Loudspeakers.....	37
PCR 5 & PCR 8 Rimless Plastic Ceiling Loudspeakers	38

100V CEILING LOUDSPEAKERS

PCR 5T & PCR 8T Rimless Plastic Ceiling Loudspeakers.....	39
PC 6T Plastic Ceiling Loudspeakers	40
PC 5T & PC 8T Plastic Ceiling Loudspeakers	41

WEATHERPROOF CEILING LOUDSPEAKERS

PC 3WP Plastic Ceiling Loudspeakers.....	43
WP 5 / WP 6 Low Impedance Plastic Ceiling Loudspeakers.....	44-45

COLUMN LOUDSPEAKERS

COM 20HP/COM 30HP High Performance Column Loudspeakers...46-47	
COM 20 / COM 40 Column Loudspeakers	48-49
COM 320 / COM 340 Column Loudspeakers.....	50-51

COM 420 & COM 440 Column Loudspeakers.....	52-53
COM SLIM 30 / COM SLIM 50 Column Loudspeakers	54-55

HORN LOUDSPEAKERS

H 15 Metal Horn Loudspeakers	57
HQ 10, HQ 15 & HQ 30 Plastic Horn Loudspeakers.....	58-59
MH 50 Two-Way Plastic Horn Loudspeakers	60
MHQ 60X Two-Way Plastic Horn Loudspeakers	61

POWERED CABINET LOUDSPEAKERS

Power Box 51 / Power Box 61 Powered Systems.....	62
Power Box 5HP Powered Systems.....	63
Power Box 5 Powered Systems	64

SOUND PROJECTORS

SPM 20HP High Performance Aluminum Sound Projectors.....	65
SP 10 Plastic Sound Projectors	66
SPMB 10 Bi-directional Aluminum Sound Projectors.....	67
SPM 20 Aluminum Sound Projectors	68

SPHERICAL LOUDSPEAKERS

SL 20M Spherical Loudspeakers	70
SL 30 Spherical Loudspeakers	71

SUBWOOFERS

SUB 100V Passive Subwoofers.....	72
SUB 2 Powered Subwoofers	73

VOLUME CONTROLS

VC 5RX / VC 30RX / VC 60RX Volume Controls	74
--	----

SPEAKER CABLES AND CONNECTORS

OF CFR Flame-retardant and oxygen free speaker cable.....	75
TCB 2 Table Connection Box	76
MK XLR / MK XLR/KL Audio cables.....	77
XLR Connectors	77
3 Pole Ceramic Terminal Block.....	77

LOUDSPEAKERS ACCESSORIES

MB1 Wall Mount Bracket for COM SLIM Loudspeakers	78
MB63 & MB65 Cluster Assemblies	78
pBOX Plastic Box for Volume Control Units.....	78
iBox Single Gang Box for VC Volume Control	79
TR-10 / TR-20 / TR-30 / TR-50 100V Line Transformers	79

Rooms *with a* View



Simple. Reliable. Profitable.

AMC® BALTIC Neries kr. 14A, LT-48397, Kaunas, Lithuania / (370 37) 308585 / www.amcpro.eu

EN54-24 CERTIFIED VOICE EVACUATION LOUDSPEAKERS

MC Voice Evacuation Speakers

Metal ceiling loudspeakers with ABS plastic dome, equipped with 100V transformer, ceramic terminal and thermal fuse.

MC 4EN

MC 4EN is designed for use in voice evacuation and voice alarm applications for clear and intelligible speech announcements. Quick fit clamps allow easy and fast installation into false ceilings. High sound pressure level SPL and optimized middle frequency sound reproduction ensures reliable operation in case of an emergency situation. Conforms EN54-24 standard.



Technical Specifications	SP 10EN
Rated power	6 W
Transformer power taps	6 W - 3 W - 1,5 W
Transformer impedance	1,67 kΩ - 3,33 kΩ - 6,66 kΩ
Sensitivity	77 dB (1W / 4 m)
Maximum SPL	84 dB (Pmax / 4m)
Frequency response	110 Hz - 15 kHz
Dispersion at 500 Hz	180° conical
Dispersion at 1000 Hz	180° conical
Dispersion at 2000 Hz	150° conical
Dispersion at 4000 Hz	100° conical
Driver dimensions	4" (100 mm)
Dimensions	ø181 mm x 67,5 mm
Weight	0,76 kg
Material	Steel
Colour	White (RAL 9016)

* Active Equalizer Applied: NO. All SPL tests are performed in a anechoic chamber.

FREQUENCY RESPONSE

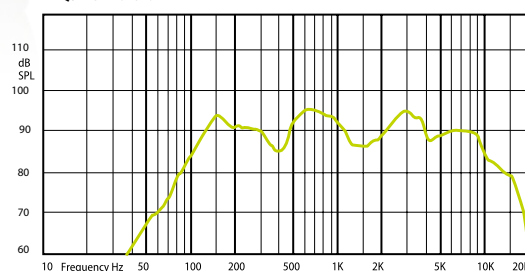

IMPEDANCE

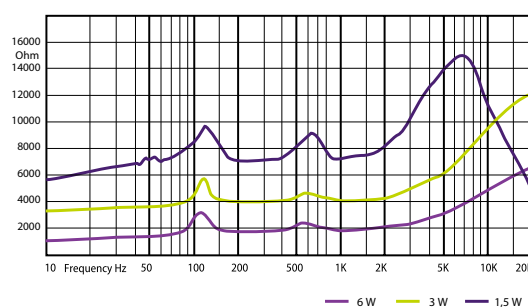

EN54-24 CERTIFIED VOICE EVACUATION LOUDSPEAKERS

iSpeak Surface Mount Plastic Loudspeakers

Plastic enclosure surface mount loudspeaker with built-in 100V line transformer.

iSpeak 5EN

iSpeak 5EN ABS plastic cabinet loudspeaker for constant voltage speaker installation systems. Effortless mounting on any surface: walls or ceilings. Modern, simple and compact form design cabinet loudspeaker with integrated 5" full range driver.

This Loudspeaker produces clear intelligible sound and is good for speech and background music applications. Especially suitable for places where loudspeakers should not make any influence to interior. Conforms EN54-24 standard.



Technical Specifications	iSpeak 5EN
Rated power	6 W
Transformer power taps	6 W - 3 W - 1,5 W
Transformer impedance	1,6 kΩ - 3,3 kΩ - 6,6 kΩ
Sensitivity	79 dB (1W / 4 m)
Maximum SPL	87 dB (Pmax / 4m)
Frequency response	200 Hz - 12 kHz
Dispersion at 500 Hz	230° (H), 230° (V)
Dispersion at 1000 Hz	180° (H), 173° (V)
Dispersion at 2000 Hz	113° (H), 115° (V)
Dispersion at 4000 Hz	75° (H), 75° (V)
Driver dimensions	5" (127 mm)
Dimensions	265 mm x 165 mm x 72 mm
Weight	1,2 kg
Material	High impact polystyrene plastic, steel grill
Colour	White (RAL 9016)

* Active Equalizer Applied: NO. All SPL tests are performed in a anechoic chamber.

FREQUENCY RESPONSE

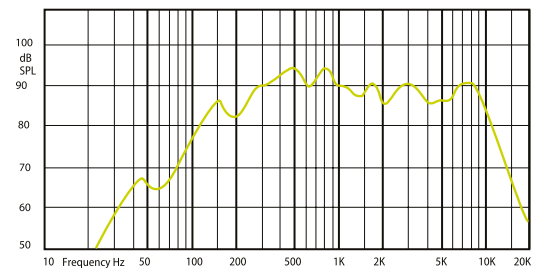

IMPEDANCE

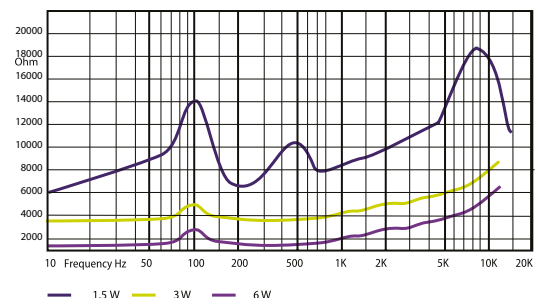

EN54-24 CERTIFIED VOICE EVACUATION LOUDSPEAKERS

SP Plastic Body Sound Projectors

Advanced design sound projectors with built-in 100V line transformer.

SP 10EN

SP 10EN is a plastic body sound projector used to provide high quality sound reproduction for music and speech, IP55 rated for heavy environmental conditions. For use in supermarkets, warehouses, factory buildings, railway stations, car parking areas and pools, wherever clear, high quality directional sound is required. Conforms EN54-24 standard.

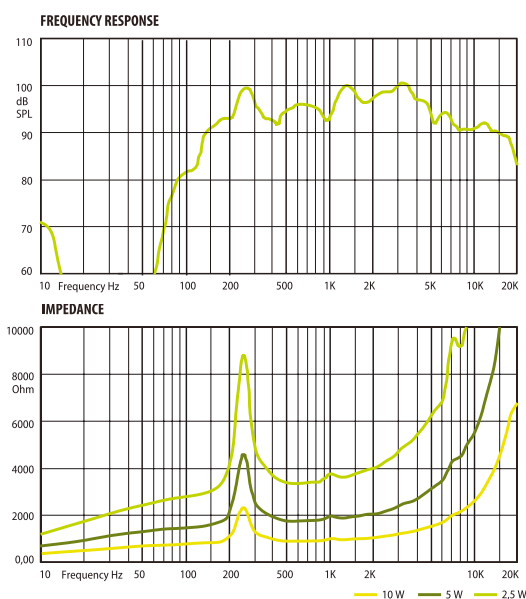
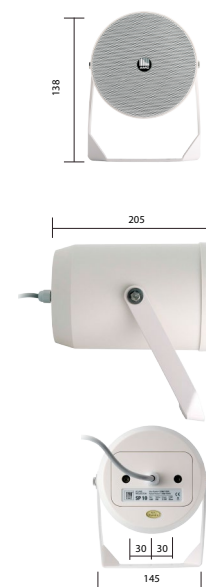

Technical Specifications	SP 10EN
Rated power	10 W
Transformer power taps	10 W - 5 W - 2,5 W
Transformer impedance	1 k Ω - 2 k Ω - 4 k Ω
Sensitivity	80 dB (1W / 4 m)
Maximum SPL	89 dB (Pmax / 4m)
Frequency response	150 Hz - 16 kHz
Dispersion at 500 Hz	360° conical
Dispersion at 1000 Hz	220° conical
Dispersion at 2000 Hz	121° conical
Dispersion at 4000 Hz	60° conical
Protection	IP 55 according CTS testing report
Dimensions	\varnothing 138 mm x 202 mm
Weight	1,6 kg
Material	ABS plastic, stainless U bracket
Colour	White (RAL 9016)

* Active Equalizer Applied: NO. All SPL tests are performed in a anechoic chamber.

EN54-24 CERTIFIED VOICE EVACUATION LOUDSPEAKERS

HQ Voice Evacuation Plastic Horn Loudspeakers

HQ 10EN robust high SPL outdoor horn loudspeaker certified according to EN54-24 standard.

HQ 10EN

HQ 10EN is designed for use in voice evacuation and voice alarm applications for clear and intelligible voice announcements. 105 dB sensitivity allows to use these horn speakers in noisy and large environments. Built-in ceramic terminal and thermal fuse ensuring faultless operation in case of an emergency situation. Horn speaker is certified by Intertek.



HORIZONTAL / VERTICAL POLAR DIAGRAMS

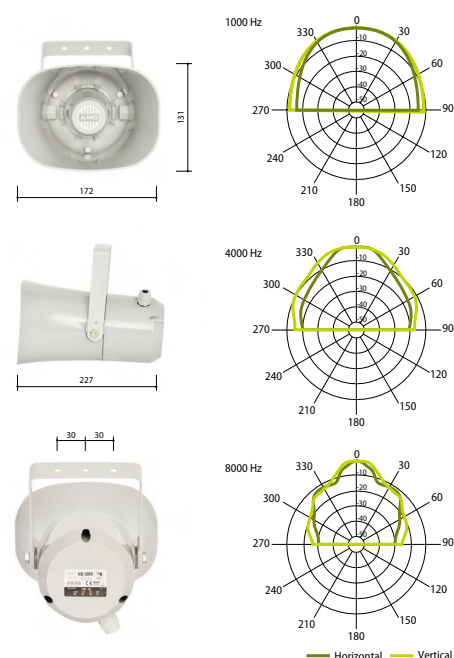

FREQUENCY RESPONSE

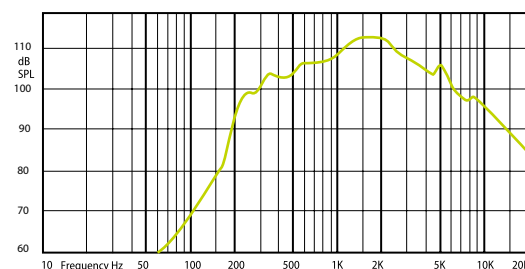

IMPEDANCE

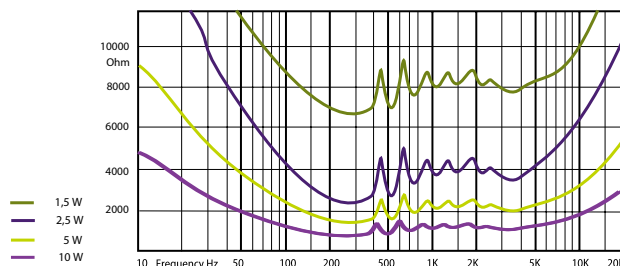

Technical Specifications	HQ 10EN
Rated power	10 W
Transformer power taps	10 W - 5 W - 2,5 W - 1,25 W
Sensitivity	105 dB (1 W/1 m)
Maximum SPL	115 dB (Pmax/1 m) at 1 kHz
Frequency response	340 Hz – 16 kHz
Dispersion at 1000 Hz	80° (H) x 105° (V)
Protection	IP 33
Dimensions	172 mm x 131 mm x 227 mm
Weight	1,6 kg
Material	Plastic horn, U type steel bracket
Colour	Light grey (RAL 7035)

EN54-24 CERTIFIED VOICE EVACUATION LOUDSPEAKERS

HQ Voice Evacuation Plastic Horn Loudspeakers

HQ 10EN robust high SPL outdoor horn loudspeaker certified according to EN54-24 standard.

HQ 15EN

HQ 15EN improved quality plastic horn speakers with extremely high SPL and a powerful middle range frequency response. Well suited for indoor and outdoor installation. For voice evacuation and paging systems.

With U-mounting bracket. Conforms EN54-24 standard.



HORIZONTAL / VERTICAL POLAR DIAGRAMS

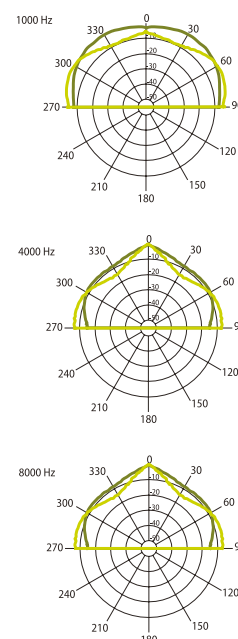

Technical Specifications	HQ 15EN
Rated power	15 W
Transformer power taps	15 W - 7,5 W
Transformer impedance	666 Ω - 1.3 kΩ
Sensitivity	89 dB (1W / 4 m)
Maximum SPL	100 dB (Pmax / 4m)
Frequency response	380 Hz - 10 kHz
Dispersion at 500 Hz	360° (H), 360° (V)
Dispersion at 1000 Hz	150° (H), 135° (V)
Dispersion at 2000 Hz	83° (H), 64° (V)
Dispersion at 4000 Hz	40° (H), 41° (V)
Protection	IP 66
Dimensions	232 mm x 222 mm x 163 mm
Weight	1,42 kg
Material	ABS plastic, U type steel bracket
Colour	White (RAL 9016)



FREQUENCY RESPONSE

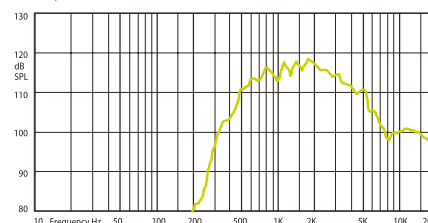

IMPEDANCE

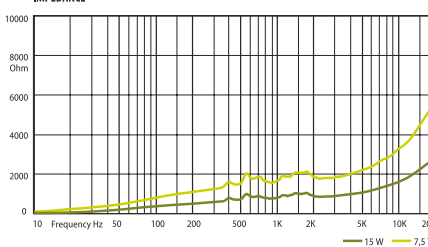

* Active Equalizer Applied: YES. All SPL tests are performed in a anechoic chamber.

630 Hz	800 Hz	5000 Hz	6300 Hz	8000 Hz	10000 Hz
+8 dB	+3 dB	+3 dB	+3 dB	+12 dB	+6 dB

CABINET LOUDSPEAKERS

iPlay Wall Mount Loudspeakers

Plastic enclosure wall mount aluminium grill cabinet loudspeakers.

iPLAY 4T, 5T & 6

iPlay is one of our most popular lines, a good sound quality and a very keen price structure means they have many applications and are used in large quantities. The range includes 4", 5" and 6" loudspeakers with corresponding tweeters. iPlay 6 is designed only for low impedance speaker lines.

Available in black and white.



Technical Specifications	iPlay 4T	iPlay 5T	iPlay 6
Rated power	30 W (8 Ω)	35 W (8 Ω)	90 W (8 Ω)
Transformer power taps	16 W - 8 W - 4 W - 2 W - 8 Ω	30 W - 16 W - 8 W - 4 W - 8 Ω	
Sensitivity	87 dB (1 W/1 m)	89 dB (1 W/1 m)	87 dB (1 W/1 m)
Maximum SPL	103 dB (Pmax/1 m) at 8137 Hz	109 dB (Pmax/1 m) at 5573 Hz	110 dB (Pmax/1 m) at 4711 Hz
Frequency response	110 Hz – 20 kHz	120 Hz – 20 kHz	70 Hz – 20 kHz
Dispersion at 1000 Hz	180° (H), 160° (V)	180° (H), 160° (V)	165° (H), 133° (V)
Driver dimensions	4" (101 mm) woofer, 1" (25 mm) tweeter	5" (127 mm) woofer, 1" (25 mm) tweeter	6" (152 mm) woofer, 1,5" (38 mm) tweeter
Dimensions	220 mm x 135 mm x 135 mm	240 mm x 165 mm x 160 mm	285 mm x 195 mm x 200 mm
Weight	1,6 kg	2,2 kg	3,2 kg
Material	Polypropylene housing with aluminum grill, U-bracket – steel	Polypropylene housing with aluminum grill, U-bracket – steel	Polypropylene housing with aluminum grill, U-bracket – steel
Colour	Papyrus white (RAL 9018) or Black (RAL 9017)	Papyrus white (RAL 9018) or Black (RAL 9017)	Papyrus white (RAL 9018) or Black (RAL 9017)

iPlay 4T

FREQUENCY RESPONSE

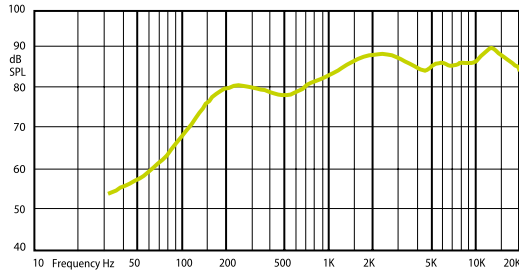

IMPEDANCE

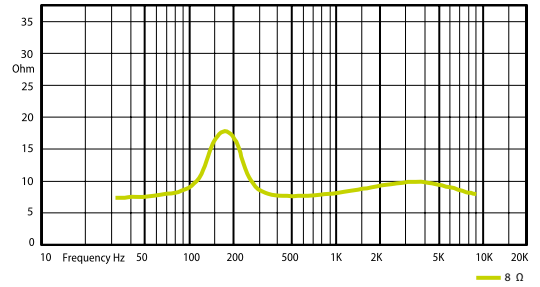

HORIZONTAL / VERTICAL POLAR DIAGRAMS

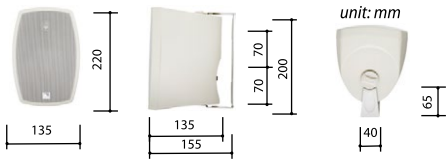
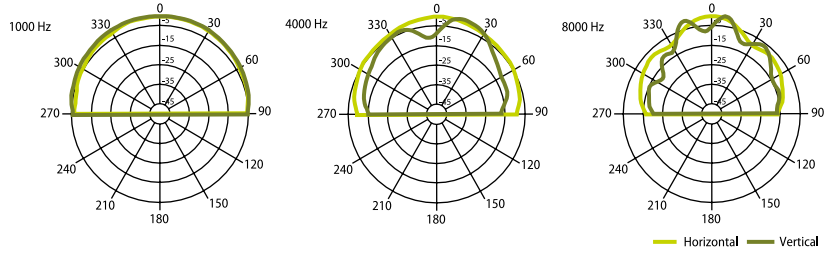

iPlay 5T

FREQUENCY RESPONSE

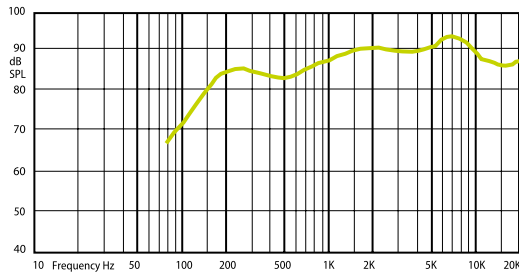

IMPEDANCE

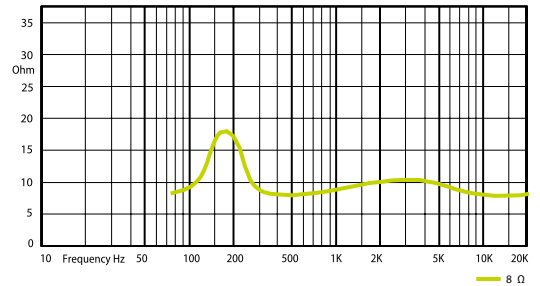

HORIZONTAL / VERTICAL POLAR DIAGRAMS

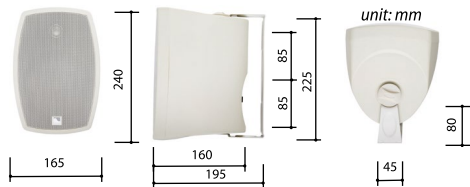
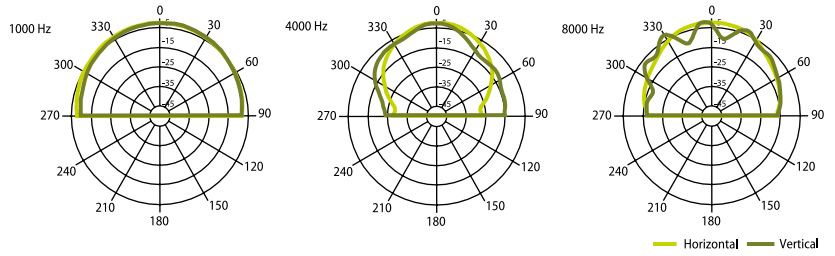

iPlay 6

FREQUENCY RESPONSE

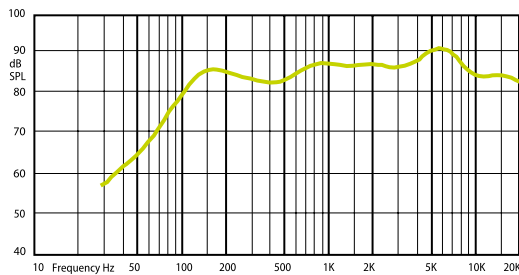

IMPEDANCE

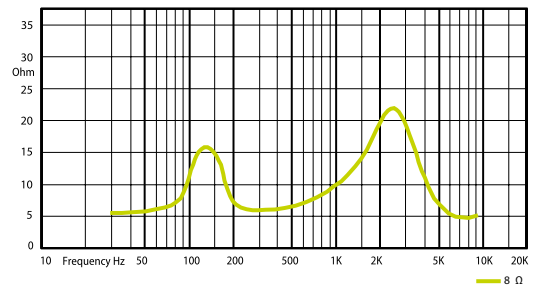

HORIZONTAL / VERTICAL POLAR DIAGRAMS

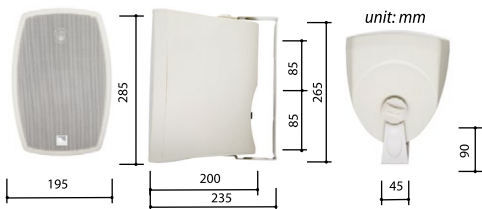
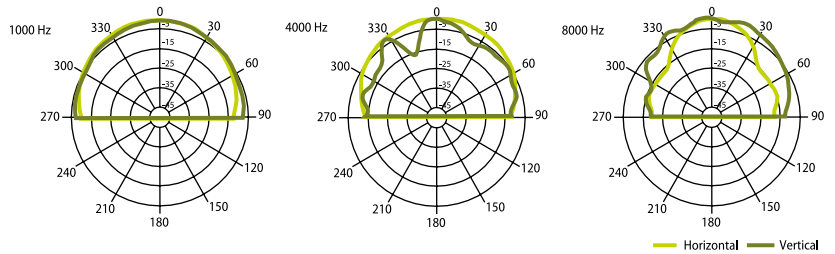

CABINET LOUDSPEAKERS

iSpeak Surface Mount Plastic Loudspeakers

Plastic enclosure surface mount loudspeaker with built-in 100V line transformer.

iSpeak 5 & iSpeak 5R

iSpeak ABS plastic cabinet loudspeakers for constant voltage speaker installation systems. Effortless mounting on any surface: walls or ceilings. Modern, simple and compact form design cabinet loudspeaker with integrated 5" full range driver.

These loudspeakers produces clear intelligible sound and is great for speech and background music applications.

Especially suitable for places where loudspeakers should not make any influence to interior.

iSpeak 5R has integrated volume attenuator. It can be used in 3 wire audio systems in order to automatically eliminate volume attenuator in emergency situations .

Technical Specifications	iSpeak 5
Rated power	6 W
Transformer power taps	6 W - 3 W - 1,5 W
Sensitivity	90 dB (1 W/1 m)
Maximum SPL	102 dB (Pmax/1 m at 2834 Hz)
Frequency response	70 Hz – 18 kHz
Dispersion at 1000 Hz	180° (H) x 140° (V)
Driver dimensions	5" (127 mm)
Dimensions	265 mm x 165 mm x 72 mm
Weight	1,2 kg
Material	High impact polystyrene plastic, steel grill
Colour	White (RAL 9016)

FREQUENCY RESPONSE

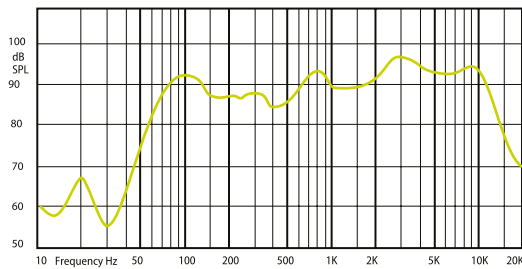

IMPEDANCE

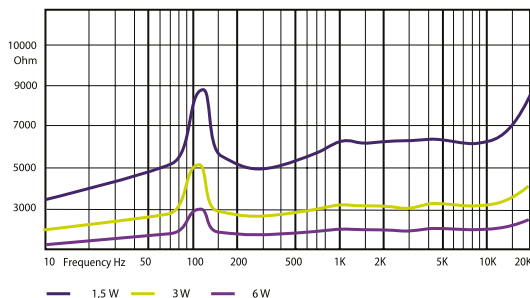

HORIZONTAL / VERTICAL POLAR DIAGRAMS

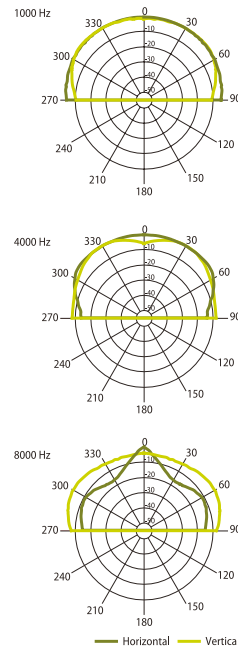

iSpeak 5

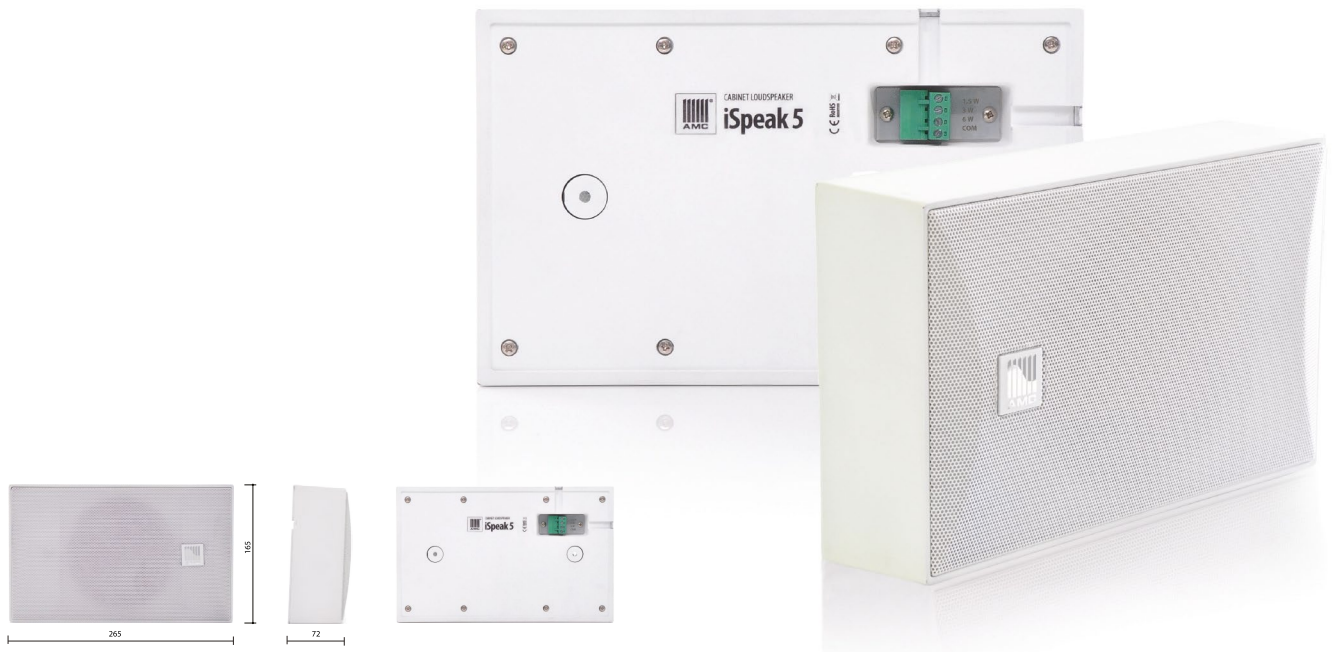

iSpeak 5R



CABINET LOUDSPEAKERS

iSpeak Surface Mount Plastic Loudspeakers

Plastic enclosure surface mount loudspeakers with built-in 100V line transformer.

iSPEAK 6

Designed to be easily and quickly mounted on any flat surface, horizontally or vertically. The enclosure features a full range speaker giving excellent speech intelligibility and is ideal for background music reproduction. It is also particularly good for applications with sensitive interiors. Available in two white shades, RAL9016 and RAL 9018.



HORIZONTAL / VERTICAL POLAR DIAGRAMS

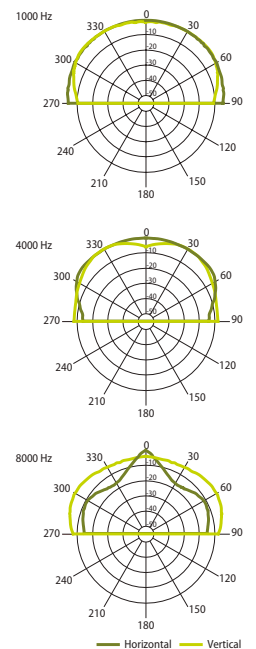

FREQUENCY RESPONSE

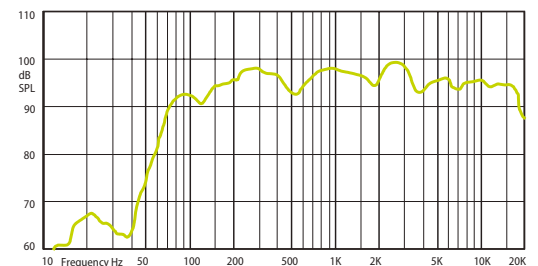

IMPEDANCE

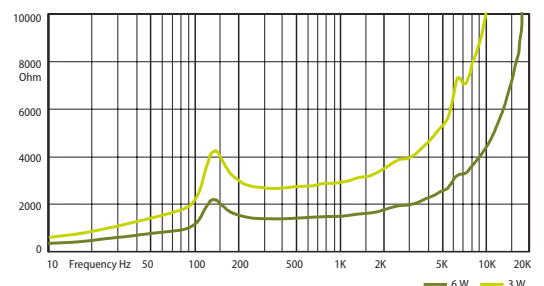

Technical Specifications	iSpeak 6
Rated power	6 W
Transformer power taps	6 W - 3 W
Sensitivity	92 dB (1 W/1 m)
Maximum SPL	99 dB (Pmax/1 m) at 2491 Hz
Frequency response	130 Hz – 17 kHz
Dispersion at 1000 Hz	180° (H), 140° (V)
Driver size	5,5" (139 mm)
Dimensions	166 mm x 267 mm x 80 mm
Weight	1 kg
Material	High impact polystyrene plastic, steel grill
Colour	Papyrus white (RAL 9018), white (RAL 9016)

CABINET LOUDSPEAKERS

PS Plastic cabinet Speakers

Plastic enclosure loudspeakers with built-in 100V line transformer.

PS 6

Neutral design round plastic enclosure cabinet loudspeaker with steel grill.
 Built-in 100V transformer. Designed for mounting on horizontal or vertical surface.
 Excellent speech intelligibility and background music reproduction.



HORIZONTAL / VERTICAL POLAR DIAGRAMS

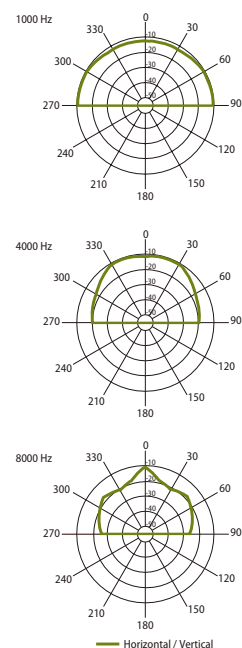

FREQUENCY RESPONSE

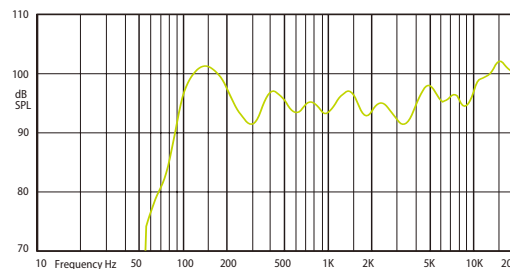

IMPEDANCE

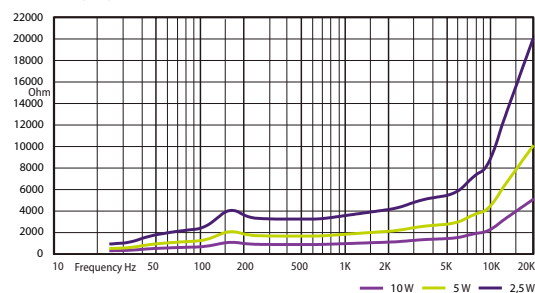

Technical Specifications	PS 6
Rated power	10 W
Transformer power taps	10 W - 5 W - 2,5 W
Sensitivity	93 dB (1W / 1m)
Maximum SPL	114 dB (Pmax / 1m) at 1425 kHz
Frequency response	80 Hz - 18 kHz
Dispersion at 1000 Hz	180° Conical
Driver dimensions	6" (152 mm)
Dimensions	ø 255 mm x 80 mm
Weight	1,3 kg
Material	ABS plastic
Colour	White (RAL 9016)

CABINET LOUDSPEAKERS

EVACW Surface Mount Voice Evacuation Loudspeakers

Metal wall mounted loudspeakers for voice evacuation systems.

EVACW 5

EVACW 5 metal enclosure loudspeakers with built-in 100V transformer. EVACW speakers are mainly used in voice evacuation systems. Thermal fuse and ceramic wire terminal are integrated to be compliant with EN54-24 standard. Full range speaker has very good medium frequency response to produce clear and intelligible speech. Simple installation on any flat surface, horizontally or vertically.

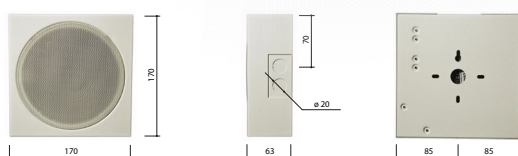

HORIZONTAL / VERTICAL POLAR DIAGRAMS

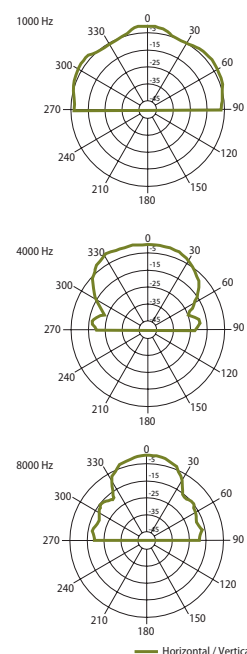

FREQUENCY RESPONSE

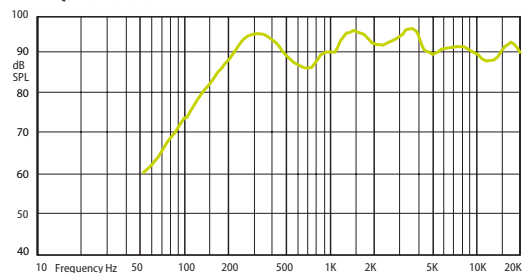

IMPEDANCE

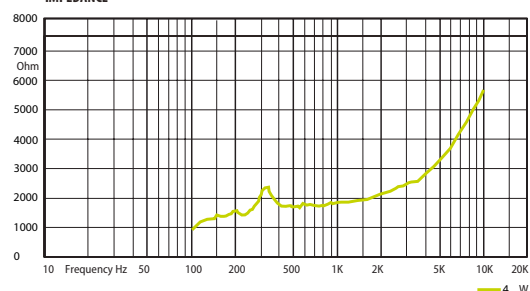

Technical Specifications	EVACW 5
Rated power	6 W (8 Ω)
Transformer power taps	6 W – 4 W – 2 W – 1 W – 0,5 W – 0,25 W
Sensitivity	92 dB (1 W/1 m)
Maximum SPL	100 dB (Pmax/1 m) at 3620 Hz
Frequency response	150 Hz – 20 kHz
Dispersion at 1000 Hz	120° (H), 120° (V)
Driver dimensions	5" (127 mm)
Dimensions	170 mm x 170 mm x 63 mm
Weight	1,4 kg
Material	Steel
Colour	White (RAL 9016)

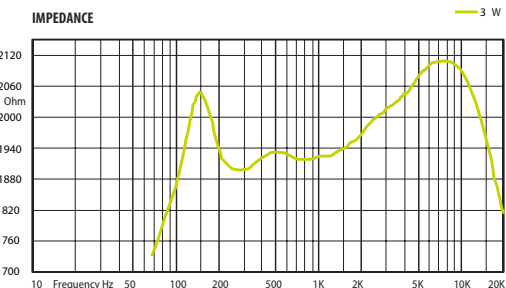
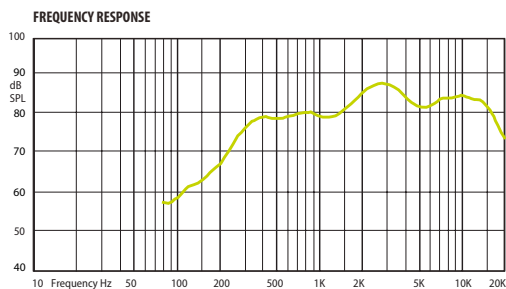

W3

HORIZONTAL / VERTICAL POLAR DIAGRAMS

HORIZONTAL / VERTICAL POLAR DIAGRAMS

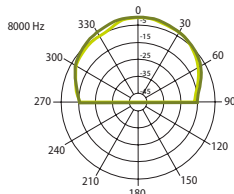
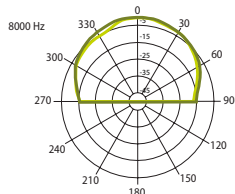
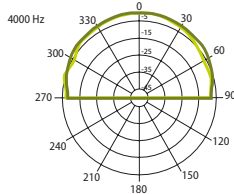
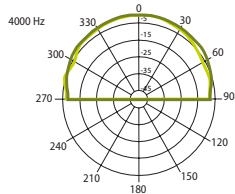
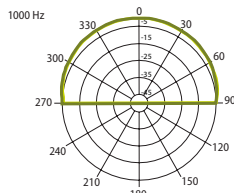
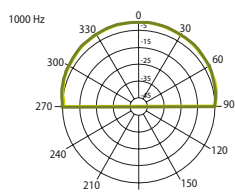

— Horizontal — Vertical

— Horizontal — Vertical

W10

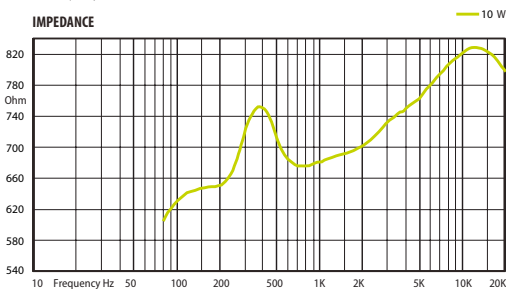
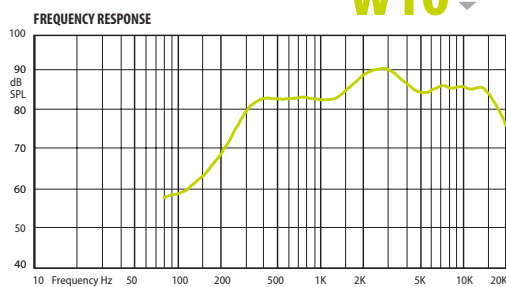

CABINET LOUDSPEAKERS

W Wall Mount Loudspeakers

W series wall mount loudspeakers.

W3 & W10

These loudspeakers are designed for use in public address and background music situations, where cost is a consideration. Small size high quality plastic cabinets with a 4" speaker and transformer inside. Good for use in hotel bathrooms, service rooms, parking areas and corridors.

Technical Specifications	W3	W10
Rated power	3 W	10 W
Transformer power taps	3 W - 1,5 W - 0,75 W	10 W - 5 W - 2,5 W
Sensitivity	84 dB (1 W/1 m)	87 dB (1 W/1 m)
Maximum SPL	93 dB (Pmax/1 m) at 1860 Hz	101 dB (Pmax/1 m) at 1815 Hz
Frequency response	200 Hz – 15 kHz	200 Hz – 15 kHz
Dispersion at 1000 Hz	180° (H), 180° (V)	180° (H), 180° (V)
Driver dimensions	4" (101 mm)	4" (101 mm)
Dimensions	185 mm x 190 mm x 90 mm	185 mm x 190 mm x 90 mm
Weight	0,6 kg	0,7 kg
Material	ABS plastic	ABS plastic
Colour	White (RAL 9016)	White (RAL 9016)



CABINET LOUDSPEAKERS

VIVA Wall Mount Plastic Loudspeakers

Latest design powerful speakers for background music.

VIVA 3

Our newest high profile loudspeaker VIVA 3 combines best design and great sound. VIVA 3 is our smallest loudspeaker with elegant mounting bracket. It has built-in high quality 3-inch precision coaxial driver with excellent sound reproduction. For those who will design 100V systems, can install this speaker directly in, the loudspeaker has built in 100V transformer. For low impedance speaker lines – 16 Ω speaker input can be selected. This allows to use more speakers in one chain. VIVA 3 was equipped with professional input and output Phoenix connectors to make installation simple and easy. Speakers are designed for use in upscale shops, restaurants, bars and other places, where high quality background music is required. In combination with our subwoofer SUB 100V, sound can be enhanced with low frequencies.

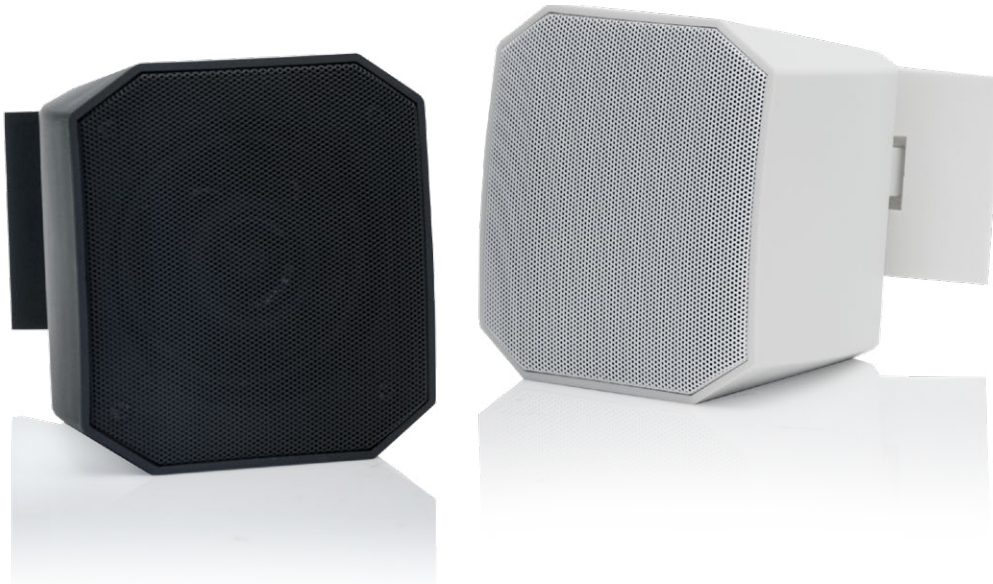

HORIZONTAL / VERTICAL POLAR DIAGRAMS

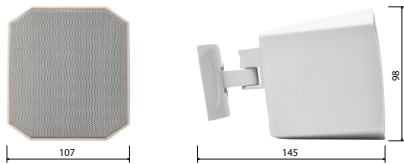
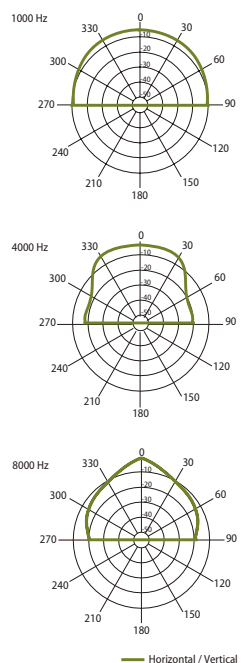

FREQUENCY RESPONSE

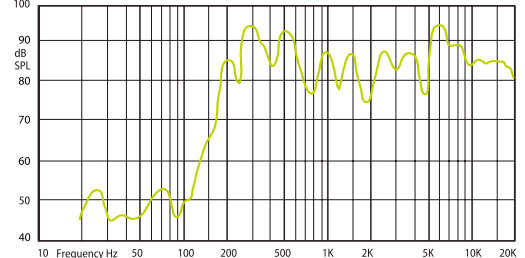

IMPEDANCE

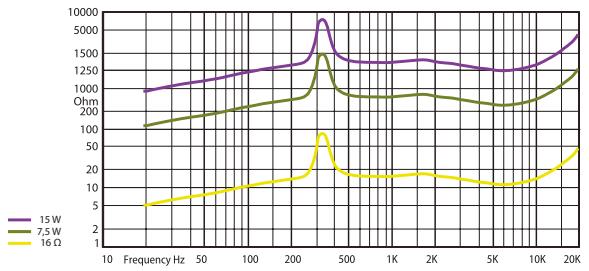

Technical Specifications		VIVA 3
Rated power		15W
Transformer power taps		15W - 7,5W - 16Ω
Sensitivity		86dB (1W/1m)
Maximum SPL		98dB (Pmax/1m) at 1000Hz
Frequency response		200Hz - 20kHz
Dispersion at 1000 Hz		180° conical
Driver dimensions		3" (72mm) woofer, 1" (25,4mm) tweeter
Dimensions		145 mm x 107 mm x 98 mm
Weight		0,9 kg
Material		Housing - plastic, grill - aluminum and U-bracket - steel
Colour		White (RAL 9016), black (RAL 9017)

CABINET LOUDSPEAKERS

VIVA Wall Mount Plastic Loudspeakers

Latest design powerful speakers for background music.

VIVA 4

VIVA 4 elegant contemporary design, smooth cabinet surface and mild grill. Classic shape with its advanced twist that lets the loudspeaker to adapt easily in a wide variety of contemporary interiors and become an integral part of the architecture.

Rotating AMC logo, semi-circle U-bracket enables a wide array of mounting possibilities. Power adjustment of the speaker is very simple. The ultra thin and flat power selector looks very elegant. Integrated Phoenix connectors show advanced design of the loudspeaker. Two colour choice. Two-way loudspeaker with 4 inch low frequency and 1 inch silk tweeter inside.



HORIZONTAL / VERTICAL POLAR DIAGRAMS

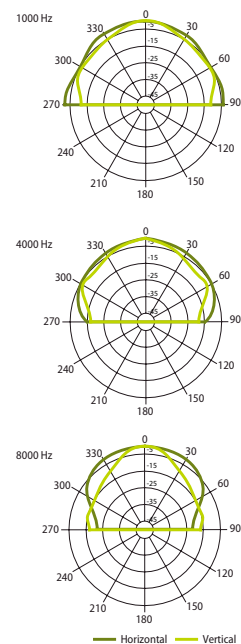

FREQUENCY RESPONSE

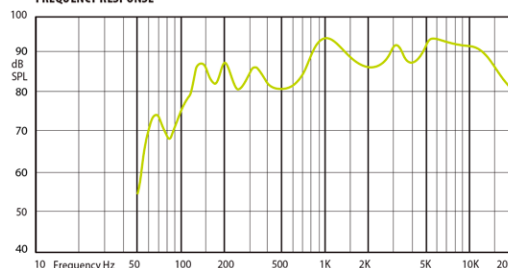

IMPEDANCE

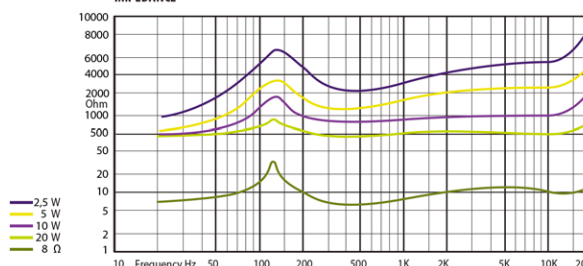

Technical Specifications	VIVA 4
Rated power	20 W
Transformer power taps	20 W - 10 W - 5 W - 2,5 W - 8 Ω
Sensitivity	89 dB (1W / 1m)
Maximum SPL	102 dB (Pmax / 1m) at 3254 Hz
Frequency response	90 Hz - 20 kHz
Dispersion at 1000 Hz	150° (H), 120° (V)
Driver dimensions	4" (101 mm) woofer, 1" (25 mm) tweeter
Dimensions	205 mm x 188 mm x 132 mm
Weight	2,1 kg
Material	Housing – plastic, grill and U-bracket – steel
Colour	White (RAL 9016), Black (RAL 9017)

CABINET LOUDSPEAKERS

VIVA Wall Mount Plastic Loudspeakers

Latest design background music loudspeaker for indoor and outdoor use.

VIVA 4IP

VIVA 4IP contemporary design cabinet loudspeaker with smooth surface. Two-way loudspeakers are equipped with 4 inch driver and 1 inch silk tweeter. The speaker is compliant with IP 55 ingress protection and can be used outdoor. Semi-circle U-mounting bracket and rotating logo enables mounting under different angles horizontally and vertically. Input power can be adjusted with selector on loudspeaker back side. In order to reach IP 55 ingress protection, wire connectors are isolated from moisture using plastic protection cover with cable gland. Available in black and white.



HORIZONTAL / VERTICAL POLAR DIAGRAMS

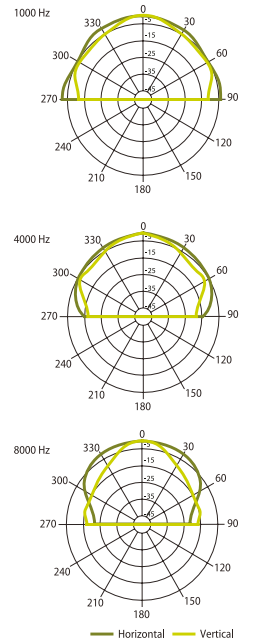

Technical Specifications	VIVA 4
Rated power	20 W
Transformer power taps	20 W - 10 W - 5 W - 2,5 W - 8 Ω
Sensitivity	89 dB (1W / 1m)
Maximum SPL	102 dB (Pmax / 1m) at 3254 Hz
Frequency response	90 Hz - 20 kHz
Dispersion at 1000 Hz	150° (H), 120° (V)
Driver dimensions	4" (101 mm) woofer, 1" (25 mm) tweeter
Dimensions	205 mm x 188 mm x 132 mm
Weight	2,1 kg
Material	Housing – plastic, grill and U-bracket – steel
Colour	White (RAL 9016), Black (RAL 9017)

FREQUENCY RESPONSE

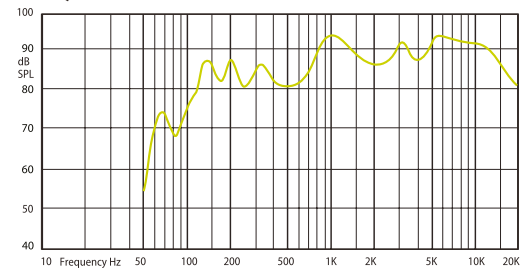

IMPEDANCE

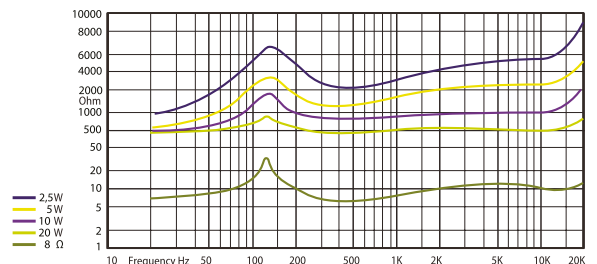

CABINET LOUDSPEAKERS

VIVA Wall Mount Plastic Loudspeakers

Latest design powerful speakers for background music.

VIVA 5

Elegant contemporary design, smooth cabinet surface with body coloured steel grill. Classic shape with advanced twist that lends this loudspeaker to adapt easily in a wide variety of contemporary interiors and become an integral part of the architecture. The newly designed semi-circular mounting bracket enables a wide array of mounting possibilities. It not only looks good, but also makes it easy to adjust the mounting angle within a 15 degree radius. The ultra thin and flat power selector looks very elegant, and the use of the integrated Phoenix connectors highlights the advanced design of the loudspeaker. The AMC logo rotates, available in white and black.

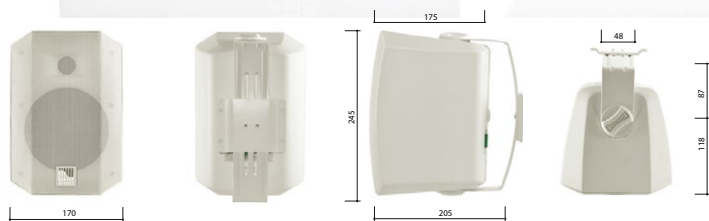

HORIZONTAL / VERTICAL POLAR DIAGRAMS

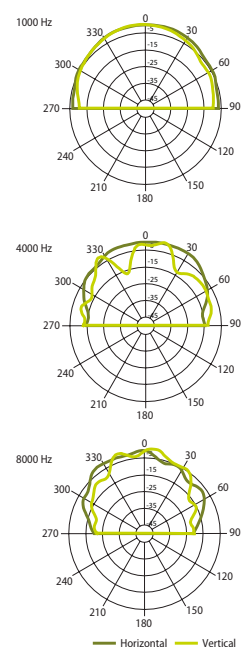

Technical Specifications	VIVA 5
Rated power	30 W
Transformer power taps	25 W - 15 W - 10 W - 5 W - 8 Ω
Sensitivity	87 dB (1 W / 1 m)
Maximum SPL	101 dB (Pmax / 1 m) at 1000 Hz
Frequency response	80 Hz - 20 kHz
Dispersion at 1000 Hz	150° (H), 120° (V)
Driver dimensions	5" (127 mm) woofer, 1" (25,4 mm) tweeter
Dimensions	245 mm x 175 mm x 170 mm
Weight	2,4 kg
Material	Housing – plastic, grill and U-bracket – steel
Colour	White (RAL 9016), Black (RAL 9017)

FREQUENCY RESPONSE

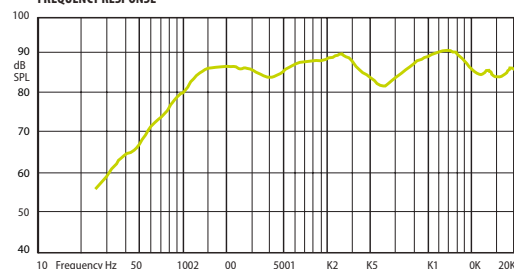

IMPEDANCE

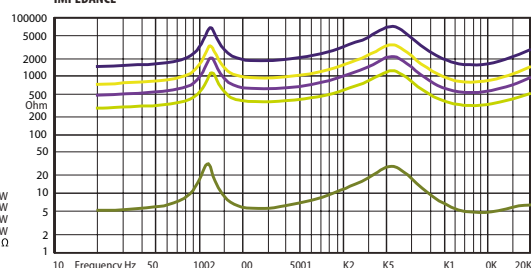

CABINET LOUDSPEAKERS

VIVA Wall Mount Plastic Loudspeakers

Latest design powerful speakers for background music.

VIVA 8

Designed for background music and paging, having a very strong, clear and powerful sound. Special mounting bracket and rotating logo allows this speaker to be mounted vertically or horizontally. 8" woofer and 1" tweeter mounted in robust ABS plastic enclosure with aluminium grill. Suitable for outdoor use.



HORIZONTAL / VERTICAL POLAR DIAGRAMS

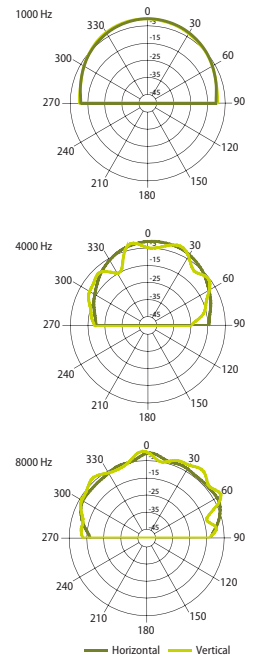

FREQUENCY RESPONSE

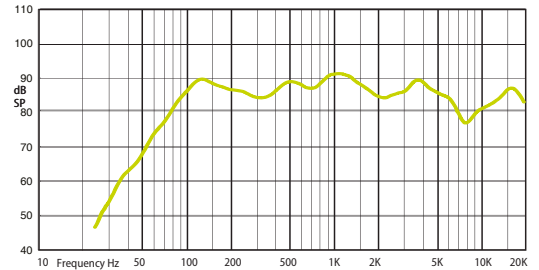

IMPEDANCE

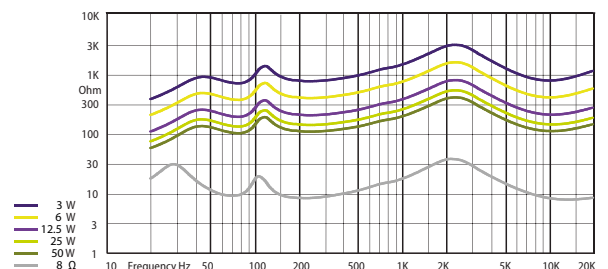

Technical Specifications	VIVA 8
Rated power	60 W (8 Ω)
Transformer power taps	50 W - 25 W - 12,5 W - 6 W - 3 W - 8 Ω
Sensitivity	87 dB (1 W/1 m)
Maximum SPL	108 dB (Pmax/1m) at 917 Hz
Frequency response	60 Hz – 20 kHz
Dispersion at 1000 Hz	120° (H), 120° (V)
Driver dimensions	8" (203mm) woofer, 1" (25,4) tweeter
Dimensions	340 mm x 220 mm x 216 mm
Weight	5,28 kg
Material	Body - plastic, grill - aluminum, U-bracket - steel
Colour	White (RAL 9016), black (RAL 9017)

CABINET LOUDSPEAKERS

VIVA Wall Mount Plastic Loudspeakers

Latest design powerful speakers for background music.

VIVA 3-302T

The legendary VIVA range of AMC cabinet loudspeakers has been in production for many years, yet is still in high demand all over the Globe. An agless cabinet design, combined with a high quality sound output makes these speakers very popular. The loudspeakers are assembled using premium components: top grade plastic parts and high quality speaker components.

Available in black and white.



HORIZONTAL / VERTICAL POLAR DIAGRAMS

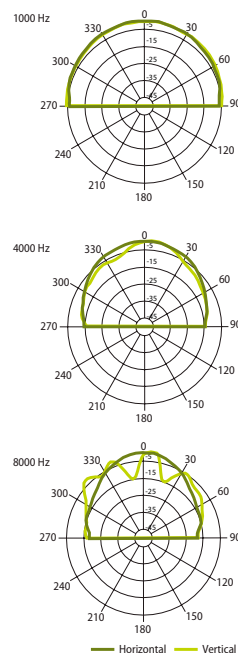

FREQUENCY RESPONSE

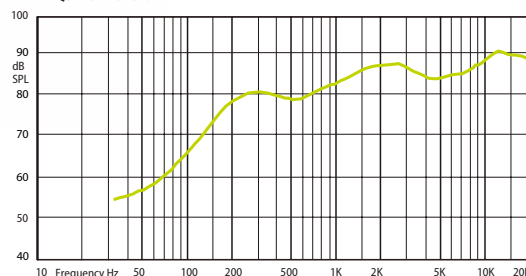

IMPEDANCE

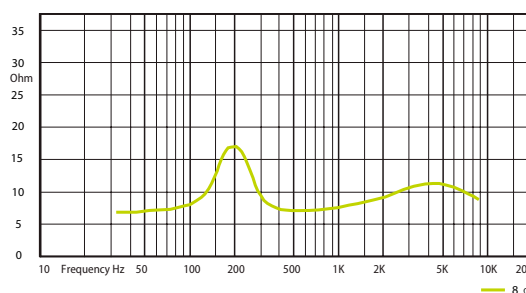

Technical Specifications	VIVA 3-302T
Rated power	25 W (8 Ω)
Transformer power taps	15 W - 7,5 W - 3 W - 8 Ω
Sensitivity	87 dB (1W / 1m)
Maximum SPL	102 dB (Pmax / 1m) at 8137 Hz
Frequency response	150 Hz - 20 kHz
Dispersion at 1000 Hz	170° (H), 180° (V)
Driver dimensions	3" (76 mm) woofer, 1" (25 mm) tweeter
Dimensions	200 mm x 113 mm x 133 mm
Weight	1,5 kg
Material	Housing – ABS plastic, U-bracket and grill – steel
Colour	White (RAL 9016), Black (RAL 9017)

CEILING LOUDSPEAKERS

MC Metal Ceiling Loudspeakers

MC - metal ceiling loudspeakers with built-in 100V transformer.

MC 4TA

Quick fit clamps allow easy and quick mounting into false ceilings. MC loudspeakers have powerful middle frequency sound reproduction and high sound pressure level (SPL). Ultra slim design of the speakers makes them ideal for installation in low space or minimum clearance situations. The MC 4TA is perfect for speech announcements in emergency systems where public address is the main requirement.



HORIZONTAL / VERTICAL POLAR DIAGRAMS

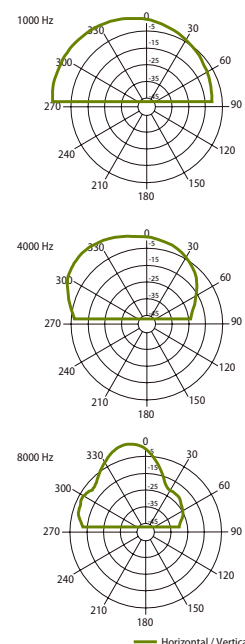

FREQUENCY RESPONSE

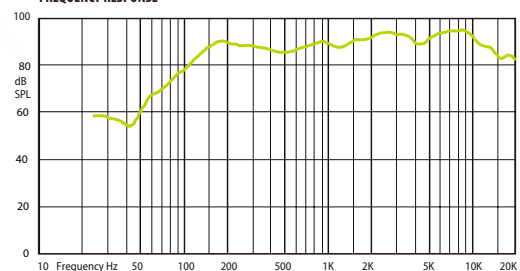

IMPEDANCE

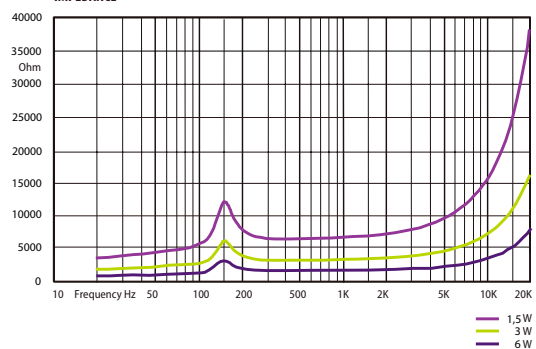

Technical Specifications	MC 4TA
Rated power	6 W
Transformer power taps	6 W - 3 W - 1,5W
Sensitivity	91 dB (1 W/1 m)
Maximum SPL	104 dB (Pmax/1 m) at 6878 Hz
Driver impedance	8 Ω
Frequency response	110 Hz – 17 kHz
Dispersion at 1000 Hz	180° conical
Driver dimensions	4" (100 mm) full range
Dimensions	Ø 180 mm × 50 mm
Weight	0,7 kg
Material	Steel
Colour	White (RAL 9016)

CEILING LOUDSPEAKERS

MC Metal Ceiling Loudspeakers

MC - metal ceiling loudspeakers with built-in 100V transformer.

MC 6T

Cost effective metal loudspeakers. Slim loudspeaker's construction designed for low installation depth, quick fit clamps allow easy and fast installation into false ceilings.

Light weight paper diaphragm and high efficiency magnet are the reasons of high performance in the middle frequency response.



HORIZONTAL / VERTICAL POLAR DIAGRAMS

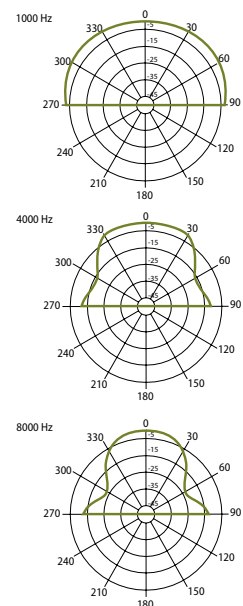

FREQUENCY RESPONSE

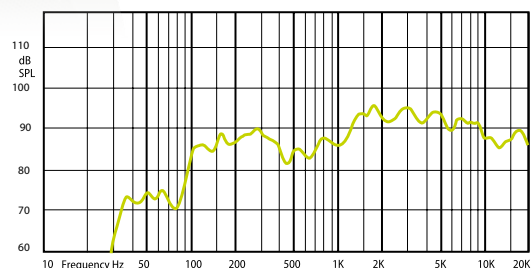

IMPEDANCE

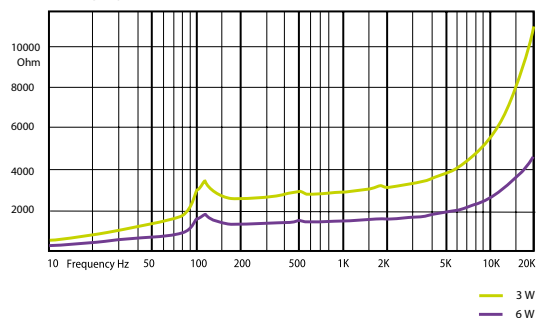

Technical Specifications	MC 6T
Rated power	6 W
Transformer power taps	6 W - 3 W
Sensitivity	92 dB (1 W/1 m)
Maximum SPL	104 dB (Pmax/1 m) at 1830 Hz
Frequency response	100 Hz - 18 kHz
Dispersion at 1000 Hz	180° conical
Driver dimensions	6" (152 mm) full range
Dimensions	ø 200 mm x 65 mm
Weight	0,9 kg
Material	Steel
Colour	White (RAL 9016)

CEILING LOUDSPEAKERS

EVAC Voice Evacuation Ceiling Loudspeakers

Metal ceiling loudspeakers with built-in 100V transformer. Steel grill and fire dome. Designed for easy mounting in to false ceilings

EVAC 50X

Designed to be installed in false ceilings or panels. EVAC 50X is perfect for use in a voice alarm role, for clear and intelligible speech reproduction as well as background music. In compliance with EN 54-24 standard, EVAC 50X is equipped with ceramic terminal and thermal fuse.

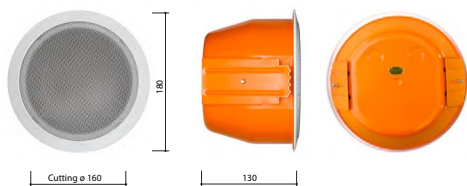

HORIZONTAL / VERTICAL POLAR DIAGRAMS

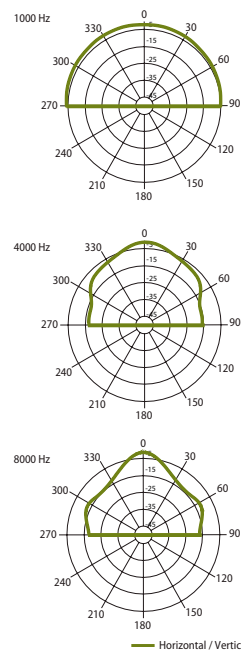

FREQUENCY RESPONSE

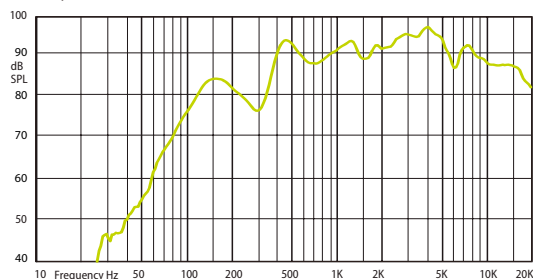

IMPEDANCE

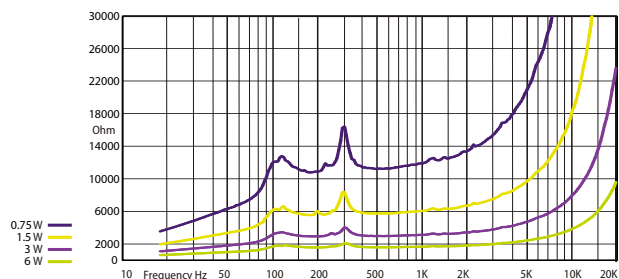

Technical Specifications	EVAC 50X
Rated power	6 W
Transformer power taps	6 W - 3 W - 1,5 W - 0,75 W - 0,25 W
Sensitivity	92 dB (1 W/1 m)
Maximum SPL	104 dB (Pmax/1 m) at 3651 Hz
Frequency response	150 Hz – 18 kHz
Dispersion at 1000 Hz	180° conical
Driver dimensions	5" (127 mm)
Dimensions	ø 180 mm x 130 mm
Weight	1,32 kg
Material	Steel
Colour	Speaker - white (RAL 9016), fire dome - orange (RAL 2008)

CEILING LOUDSPEAKERS

PC Low Impedance Ceiling Loudspeakers

High performance coaxial ceiling loudspeakers.

PC 6

These specially designed speakers are ideal for back ground music with a high SPL. The enclosures are assembled using high quality materials and coupled to a very high quality coaxial speaker. Used in environments where excellent sound quality and a high SPL is required: bars, restaurants, modern shops.

The clear and neutral design of this enclosure loudspeaker allows it to blend into any interior.



HORIZONTAL / VERTICAL POLAR DIAGRAMS

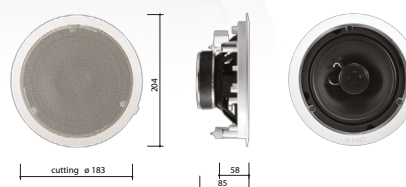
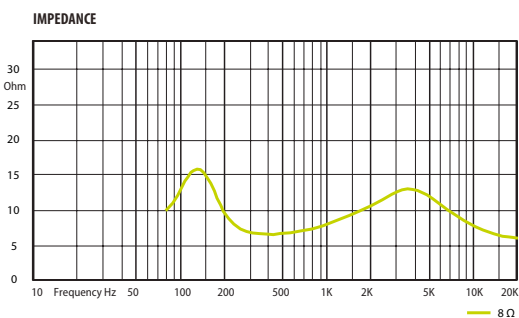
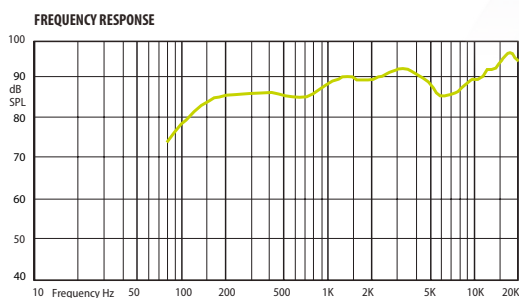
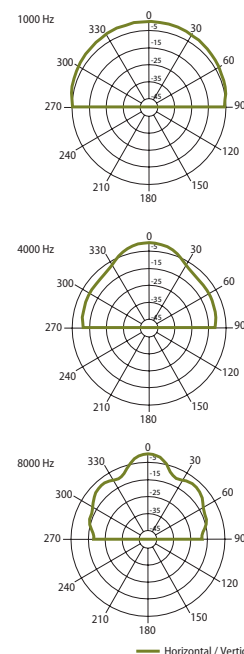

Technical Specifications	PC 6
Rated power	50 W (8 Ω)
Sensitivity	90 dB (1 W/1 m)
Maximum SPL	109 dB (Pmax/1 m) at 2638 Hz
Frequency response	80 Hz – 20 kHz
Dispersion at 1000 Hz	180° conical
Driver dimensions	6" (152mm) woofer, 1,25" (32mm) tweeter
Dimensions	∅ 204 mm x 85 mm
Weight	1,4 kg
Material	Housing - ABS plastic, grill - steel
Colour	White (RAL 9016)



SERVE A RICH SOUND

PC 6HP | Speakers

A beautifully designed, rimless ceiling speaker, for superior background sound reproduction in top class establishments such as stores, hotels and offices.

Simple. Reliable. Profitable.

www.amcpro.eu

CEILING LOUDSPEAKERS

PC Low Impedance Ceiling Loudspeakers

High performance coaxial ceiling loudspeakers

PC 6 HP

PC 6HP high performance 8 Ω ceiling loudspeakers for low impedance background music systems. Metall grill with magnetic fixing are specially made with extra slim plastic edge in order to make minimum intervention to interior. Adjustable silk tweeters angle allow precisely match high frequency performance in any living area and let you to choose your preferred kind of high frequency sound: directly or reflected. PC 6HP are specially made without 100V transformers for the excellent clear and dynamic sound. These 35W coaxial loudspeakers can be quickly and simply installed into false ceilings by using four points fastening system. PC 6HP is a strong and powerful sound reproduction loudspeaker that has almost unlimited applications for home background music, as well for public spaces where high quality background music needed.



HORIZONTAL / VERTICAL POLAR DIAGRAMS

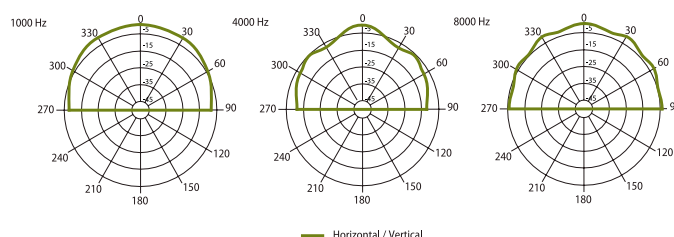

— Horizontal / Vertical

FREQUENCY RESPONSE

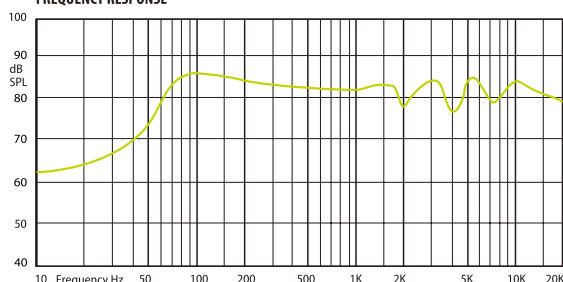

IMPEDANCE

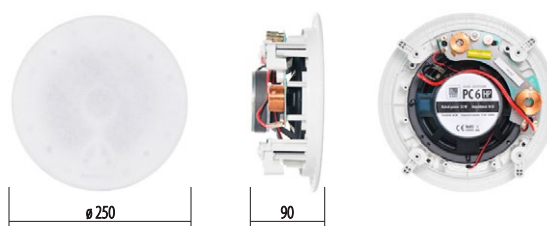
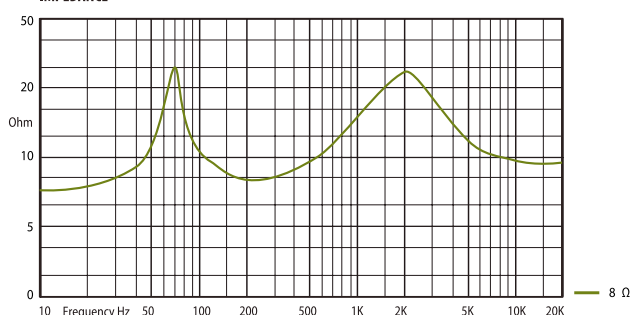

Technical Specifications	PC 6 HP
Rated power	35 W
Impedance	8 Ω
Sensitivity	86 dB (1 W/1 m)
Maximum SPL	102 dB (Pmax / 1m)
Frequency response	75 Hz - 20 kHz
Dispersion at 1000 Hz	150° conical
Driver dimensions	6,5" (165 mm)
Dimensions	Ø 250 mm x 90 mm
Weight	7 kg
Material	Housing - plastic, grill - steel
Colour	White (RAL 9016)

CEILING LOUDSPEAKERS

PCR Rimless Plastic Ceiling Loudspeakers

ABS plastic ceiling loudspeakers for low impedance audio.

PCR 5 & PCR 8

Loudspeaker coil is specially made 16 ohm in order to use more speakers in one chain.

16 ohm allows connect two speakers in parallel and have 8ohm load, or connect even 4 and use system with 4ohm professional audio amplifier or stereo receiver.



FREQUENCY RESPONSE

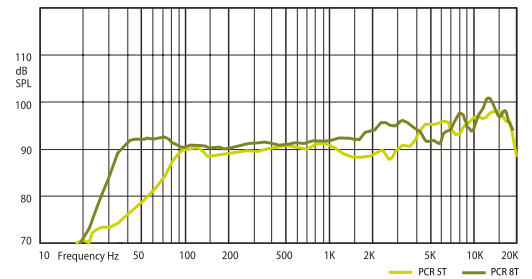

IMPEDANCE

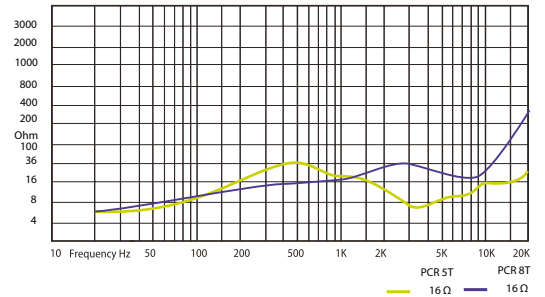

HORIZONTAL / VERTICAL POLAR DIAGRAMS

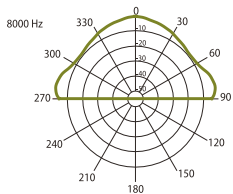
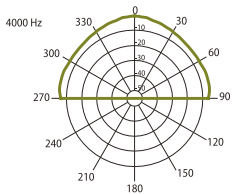
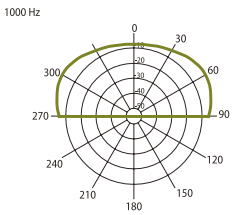

— Horizontal / Vertical



	PCR 5	PCR 8
Rated power	25 W (16 Ω)	35 W (16 Ω)
Sensitivity	89 dB (1 W/1 m)	90 dB (1 W/1 m)
Maximum SPL	101dB (Pmax/1 m) at 15694 Hz	105 dB (Pmax/1 m) at 15249 Hz
Frequency response	80 Hz – 20 kHz	60 Hz – 20 kHz
Dispersion at 1000 Hz	120° conical	120° conical
Driver dimensions	5" (130 mm) woofer, 0,5" (13 mm) tweeter, coaxial	8" (200 mm) woofer, 0,5" (13 mm) tweeter, coaxial
Dimensions	ø 200 mm × 70 mm	ø 250 mm × 95 mm
Weight	0.85 kg	1.4 kg
Material	Plastic, Steel grill	Plastic, Steel grill
Colour	White (RAL 9016)	White (RAL 9016)

CEILING LOUDSPEAKERS

PCR Rimless Plastic Ceiling Loudspeakers

ABS plastic ceiling loudspeakers with built-in 100V transformer.

PCR 5T & PCR 8T

Excellent coaxial speakers for improved sound quality with new rimless enclosure design. Rimless grill with magnetic grill fixings lets easily and quickly install into false ceilings. Minimalistic design approved for sensitive interiors.



FREQUENCY RESPONSE

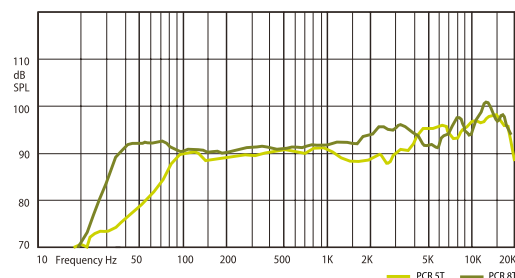

IMPEDANCE

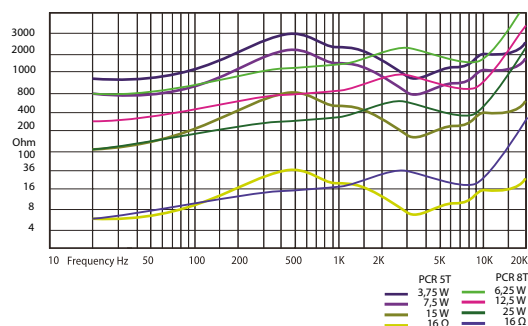

HORIZONTAL / VERTICAL POLAR DIAGRAMS

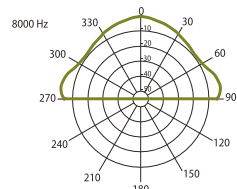
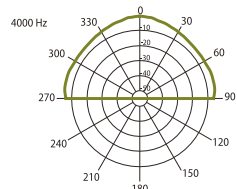
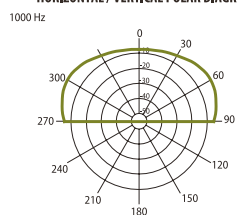

— Horizontal / Vertical

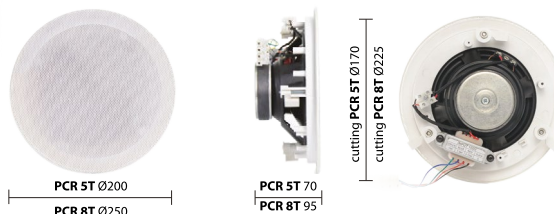

	PCR 5T	PCR 8T
Rated power	25 W (16 Ω)	35 W (16 Ω)
Transformer power taps	15 W - 7,5 W - 3,75 W	25 W - 12,5 W - 6,25 W
Sensitivity	89 dB (1 W/1 m)	90 dB (1 W/1 m)
Maximum SPL	101dB (Pmax/1 m) at 15694 Hz	105 dB (Pmax/1 m) at 15249 Hz
Frequency response	80 Hz – 20 kHz	60 Hz – 20 kHz
Dispersion at 1000 Hz	120° conical	120° conical
Driver dimensions	5" (130 mm) woofer, 0,5" (13 mm) tweeter, coaxial	8" (200 mm) woofer, 0,5" (13 mm) tweeter, coaxial
Dimensions	ø 200 mm × 70 mm	ø 250 mm × 95 mm
Weight	1,1 kg	1,7 kg
Material	Plastic, Steel grill	Plastic, Steel grill
Colour	White (RAL 9016)	White (RAL 9016)

CEILING LOUDSPEAKERS

PC Plastic Ceiling Loudspeakers

PC - plastic ceiling loudspeakers with built-in 100V transformer.

PC 6T

Cost effective ABS plastic loudspeaker. Designed to be quickly and simply installed into false ceilings.
 Cost saving solution for PA systems where large amount of speakers is required. Excellent full range loudspeaker for systems where combination of background music and voice announcements are required.



HORIZONTAL / VERTICAL POLAR DIAGRAMS

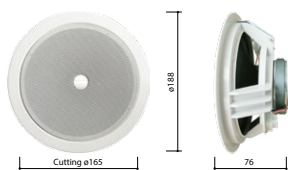
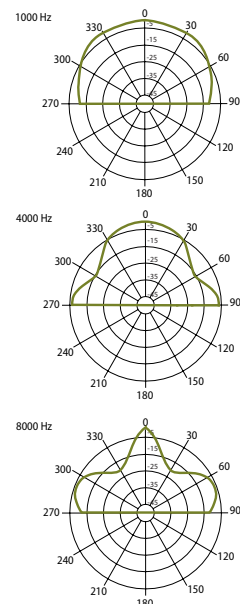

Technical Specifications	PC 6T
Rated power	6 W
Transformer power taps	6 W - 3 W
Sensitivity	93 dB (1 W/1 m)
Maximum SPL	100 dB (Pmax/1 m)
Frequency response	100 Hz – 15 kHz
Dispersion at 1000 Hz	180° conical
Driver dimensions	6" (152 mm)
Dimensions	ø 188 mm x 76 mm
Weight	0,7 kg
Material	Plastic, Steel grill
Colour	White (RAL 9016)

FREQUENCY RESPONSE

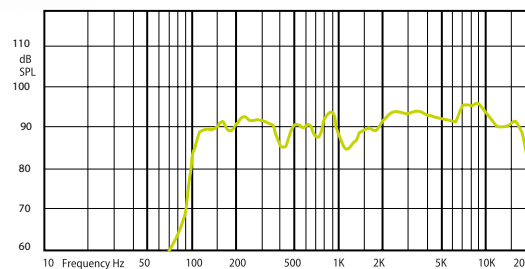

IMPEDANCE

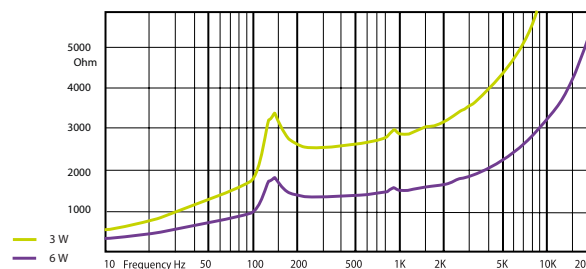

CEILING LOUDSPEAKERS

PC Plastic Ceiling Loudspeakers

PC - plastic ceiling loudspeakers with built-in 100V transformer.

PC 5T & PC 8T

These units provide an excellent full range of clear sound reproduction. Used where a combination of high quality background music and public address is required. The loudspeakers are designed to be quickly and simply installed into false ceilings and are equipped with coaxial speakers for improved sound quality.



FREQUENCY RESPONSE

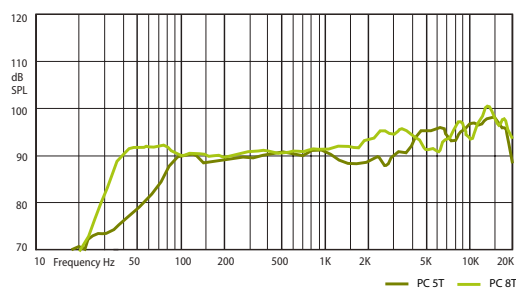

IMPEDANCE

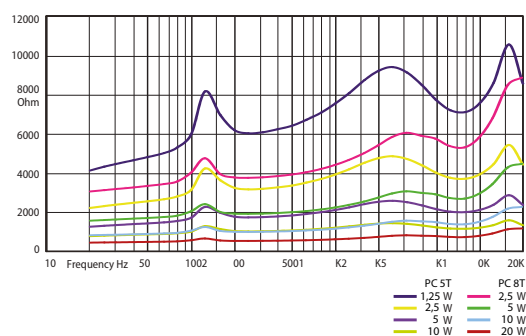

HORIZONTAL / VERTICAL POLAR DIAGRAMS

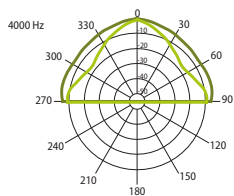
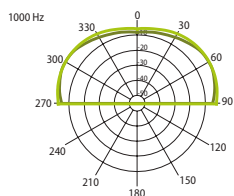

— PC 5T Horizontal / Vertical
— PC 8T Horizontal / Vertical

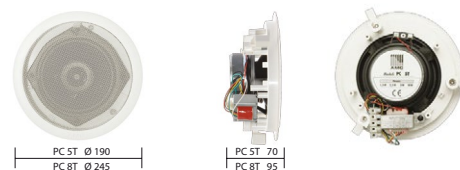

Technical Specifications	PC 5T	PC 8T
Rated power	10 W	20 W
Transformer power taps	10 W - 5 W - 2.5 W - 1.25 W	20 W - 10 W - 5 W - 2.5 W
Sensitivity	88 dB (1 W/1 m)	88 dB (1 W/1 m)
Maximum SPL	98 dB (Pmax/1 m) at 15694 Hz	101 dB (Pmax/1 m) at 15249 Hz
Frequency response	90 Hz – 20 kHz	80 Hz – 20 kHz
Dispersion at 1000 Hz	120° conical	120° conical
Driver dimensions	5" (130 mm) woofer, 0.5" (13 mm) tweeter, coaxial	8" (130 mm) woofer, 0.5" (13 mm) tweeter, coaxial
Dimensions	ø 190 mm x 70 mm	ø 245 mm x 95 mm
Weight	1.1 kg	2.1 kg
Material	Plastic, Steel grill	Plastic, Steel grill
Colour	White (RAL 9016)	White (RAL 9016)



Sound
to **Dive in**



Simple. Reliable. Profitable.

WEATHERPROOF CEILING LOUDSPEAKERS

PC Plastic Ceiling Loudspeakers

Plastic ceiling loudspeakers with integrated 100 V line transformer and plastic dome.

PC 3WP

The PC 3WP plastic weatherproof loudspeaker has a plastic dome and a high quality 3" speaker inside. While small in size this 6 W speaker delivers perfect clarity across the full range. The PC 3WP is mainly used in public spaces, where ceilings are relatively low and interiors are sensitive to any kind of external influence Ideal for paging and background music applications



HORIZONTAL / VERTICAL POLAR DIAGRAMS

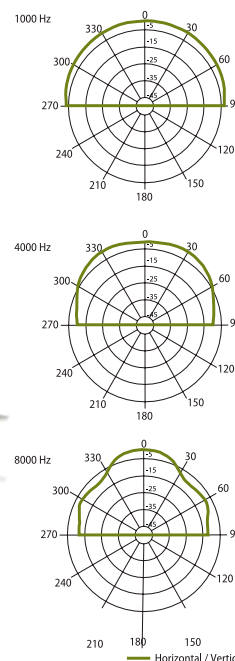

FREQUENCY RESPONSE

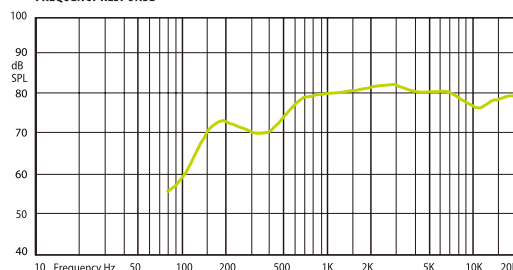

IMPEDANCE

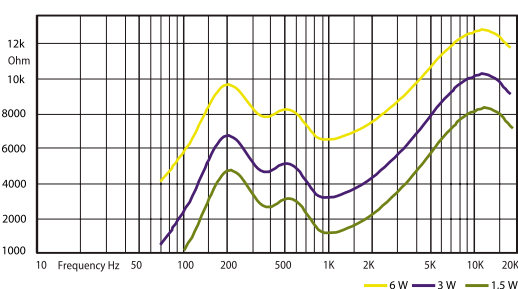

Technical Specifications	PC 3WP
Rated power	6 W
Transformer power taps	6 W - 3 W - 1,5 W
Sensitivity	81 dB (1 W / 1 m)
Maximum SPL	91 dB (Pmax / 1 m) at 2420 Hz
Frequency response	150 Hz - 20 kHz
Dispersion at 1000 Hz	180° conical
Driver dimensions	3" (76 mm)
Protections	IP54
Dimensions	Ø115 mm x 90 mm
Weight	385 g
Material	Plastic, steel grill
Colour	White (RAL 9016)

WEATHERPROOF CEILING LOUDSPEAKERS

WP Low Impedance Ceiling Loudspeakers

Weatherproof ceiling loudspeakers

WP 5 & WP 6

WP 5 & WP 6 ceiling loudspeakers - unique combination of clear sound and special design of weatherproofness. Incredibly reliable, durable and universal WP5 & WP6 are 5 and 6 inch two way loudspeakers with plastic speaker membrane, moisture isolated magnet and speaker coil. These loudspeakers are designed for installations in the hard climate conditions and extremely moisture environments. Loudspeaker has removable plastic grill which hides speakers mounting screws and enclosure looks elegant when mounted in ceilings. Designed for low impedance systems. These loudspeakers are ideal solution for background music in SPA centers, indoor pools, showers, sauna and ships.



Technical specifications	WP 5	WP 6
Rated power	40 W	50 W
Impedance	4 Ω	4 Ω
Sensitivity	89 dB (1 W/1 m)	90 dB (1 W/1 m)
Maximum SPL	105 dB (Pmax/1 m)	106 dB (Pmax/1 m)
Frequency response	80 Hz - 20 kHz	70 Hz - 20 kHz
Dispersion at 1000 Hz	120° conical	120° conical
Driver dimensions	5" (130 mm) woofer, 0,5" (13 mm) tweeter, coaxial	6" (152 mm) woofer, 0,5" (13 mm) tweeter, coaxial
Dimensions	ø 165 mm x 90 mm	ø 191 mm x 100 mm
Weight	0,8 kg	1 kg
Material	Plastic	Plastic
Colour	White (RAL 9016)	White (RAL 9016)

WP 5

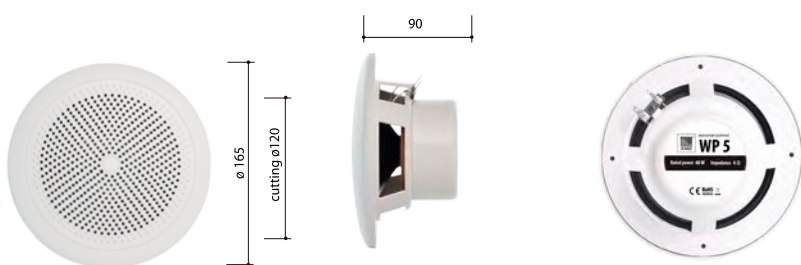

WP 5 FREQUENCY RESPONSE

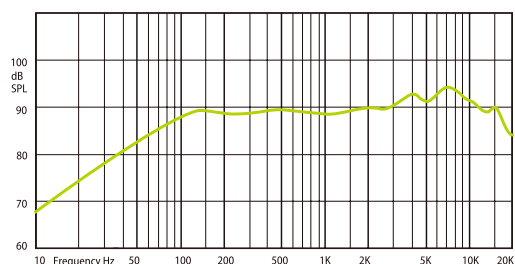

HORIZONTAL / VERTICAL POLAR DIAGRAMS

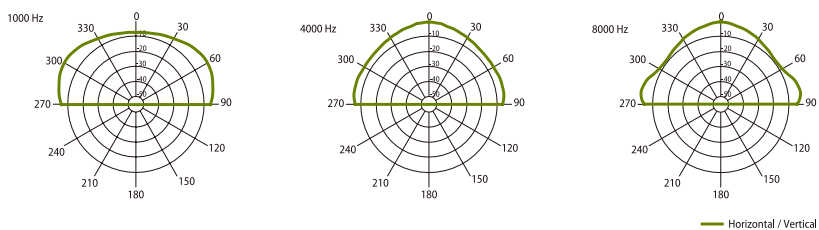

IMPEDANCE

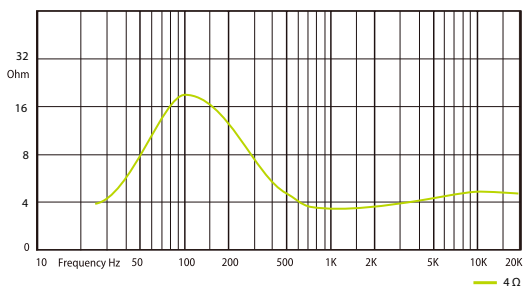

WP 6

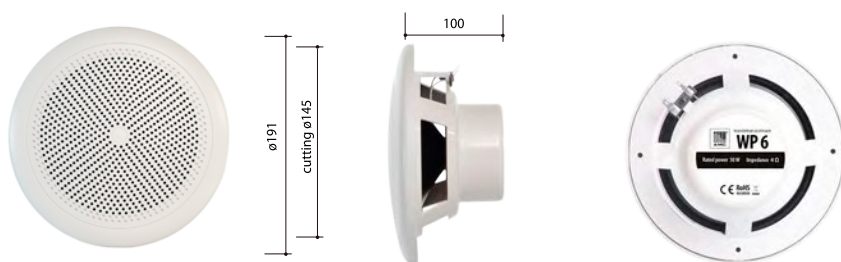

WP 6 FREQUENCY RESPONSE

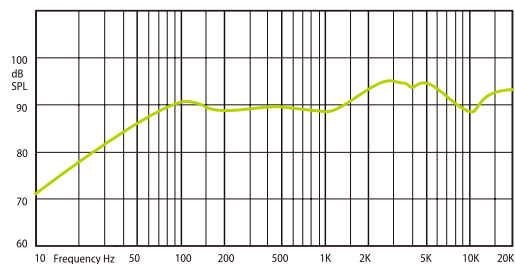

HORIZONTAL / VERTICAL POLAR DIAGRAMS

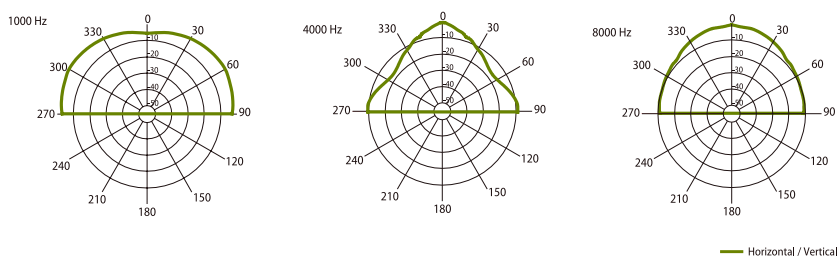

IMPEDANCE

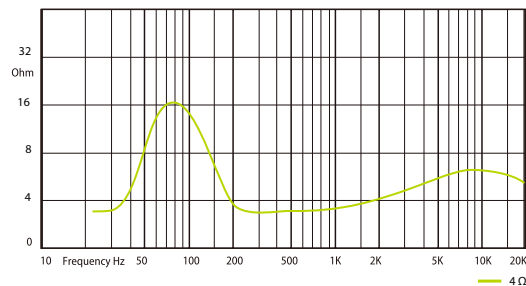

COLUMN LOUDSPEAKERS

COM HP High Performance Column Loudspeakers

COM HP aluminum body high performance outdoor column loudspeakers.

COM 20HP & COM 30HP

Wide frequency response and high SPL loudspeakers. Special bracket for precise speaker mounting.
 Typical application: railway stations, subways, churches, factory buildings, warehouses, parking lots, open air spaces.



Technical Specifications	COM 20 HP
Rated power	20 W
Transformer power taps	20 W - 10 W - 5 W - 2,5 W
Sensitivity	92 dB (1 W/1 m)
Maximum SPL	110 dB (Pmax/1 m) at 14125 Hz
Frequency response	120 Hz – 20 kHz
Dispersion at 1000 Hz	180° (H), 80° (V)
Protection	IP 66
Dimensions	585 mm × 125 mm x 110 mm
Driver dimensions	4 x 3,5" (88 mm) woofer, 0,8" (20 mm) tweeter
Weight	5 kg
Material	Aluminum
Colour	White (RAL 9016)

	COM 30 HP
	30 W
	30 W - 15 W - 7,5 W - 3,75 W
	94 dB (1 W/1 m)
	112 dB (Pmax/1 m) at 11220 Hz
	110 Hz – 20 kHz
	180° (H), 70° (V)
	IP 66
	775 mm × 125 mm x 110 mm
	6 x 3,5" (88 mm) woofer, 0,8" (20 mm) tweeter
	7 kg
	Aluminum
	White (RAL 9016)

COM 20HP

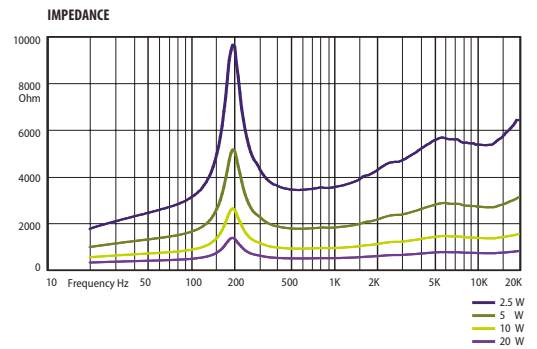
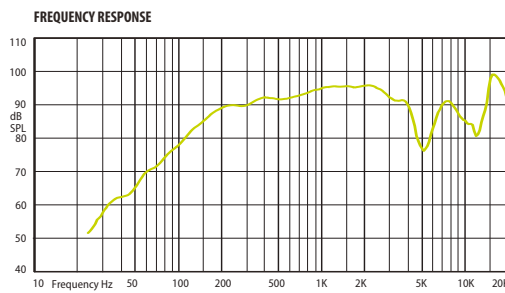

HORIZONTAL / VERTICAL POLAR DIAGRAMS

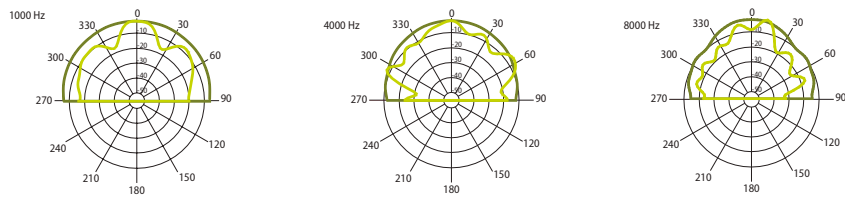

COM 30HP

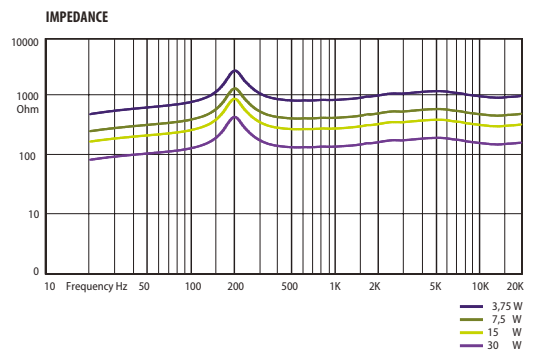
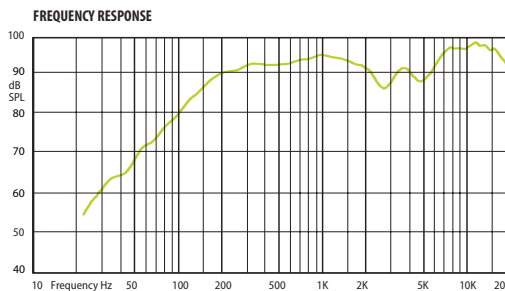

HORIZONTAL / VERTICAL POLAR DIAGRAMS

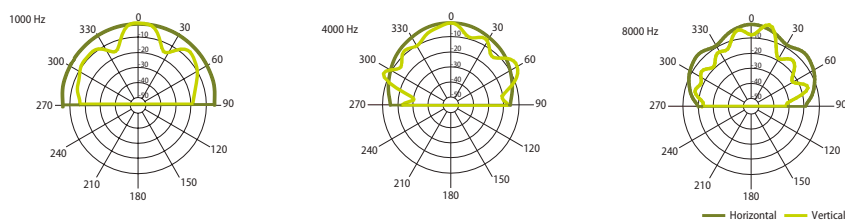

COLUMN LOUDSPEAKERS

COM Weatherproof Column Loudspeakers

COM aluminum body outdoor column loudspeakers.

COM 20 & COM 40

Wide frequency response and high sensitivity loudspeakers are ideal for speech and background music reproduction in large areas, where a simple and reliable solution is needed. Can be used in heavy weather conditions. **COM 20** is manufactured with two 5"(127 mm) full range speakers, **COM 40** has four 5"(127 mm) full range speakers.



Technical Specifications	COM 20	COM 40
Rated power	20 W	40 W
Transformer power taps	20 W - 10 W	40 W - 20 W
Sensitivity	92 dB (1 W/1 m)	94 dB (1 W/1 m)
Maximum SPL	105 dB (Pmax/1 m) at 1179 Hz	110 dB (Pmax/1 m) at 1113 Hz
Frequency response	100 Hz – 15 kHz	100 Hz – 15 kHz
Dispersion at 1000 Hz	180° (H), 150° (V)	180° (H), 150° (V)
Protection	IP 54	IP 54
Dimensions	378 mm × 151 mm x 125 mm	618 mm × 151 mm x 125 mm
Driver dimensions	2 x 5" (127 mm)	4 x 5" (127 mm)
Weight	2,9 kg	4,7 kg
Material	Aluminum	Aluminum
Colour	Grey (RAL 7038)	Grey (RAL 7038)

COM 20



HORIZONTAL / VERTICAL POLAR DIAGRAMS

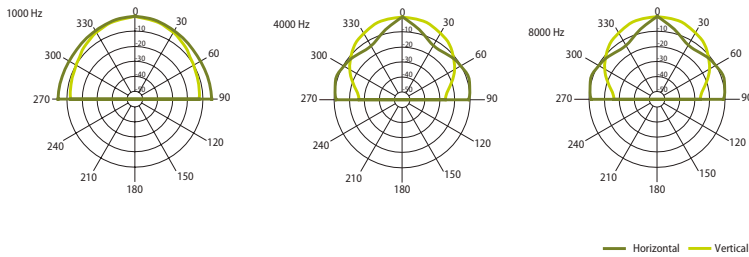

FREQUENCY RESPONSE

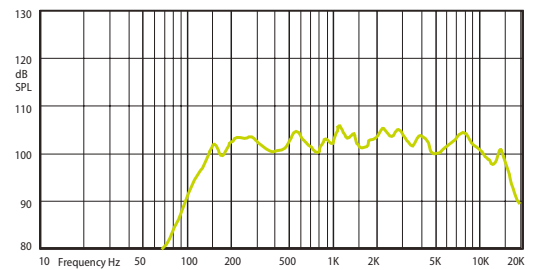

IMPEDANCE

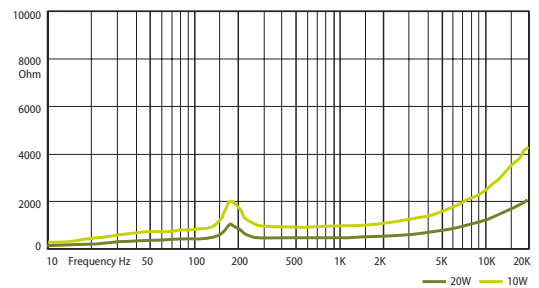

COM 40

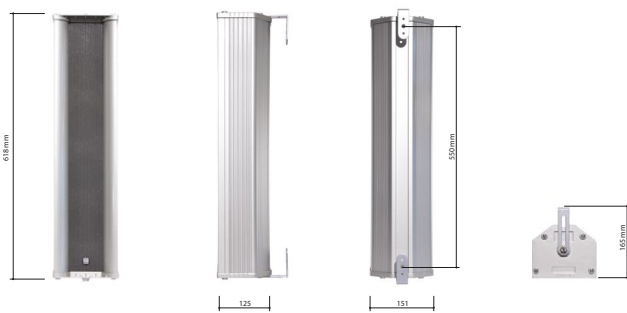

HORIZONTAL / VERTICAL POLAR DIAGRAMS

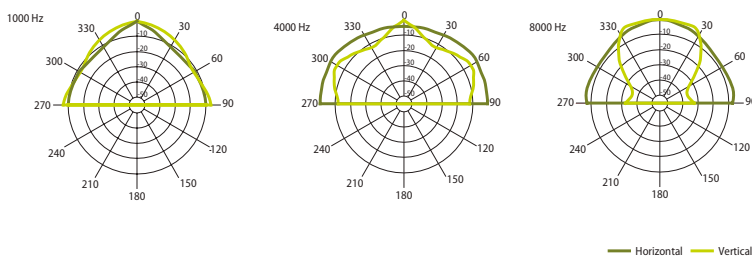

FREQUENCY RESPONSE

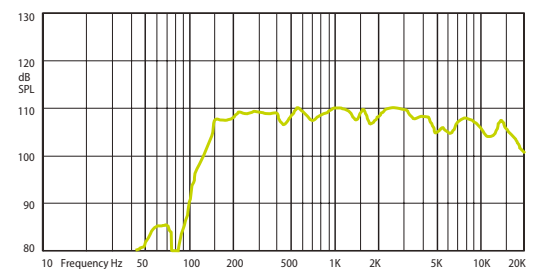

IMPEDANCE

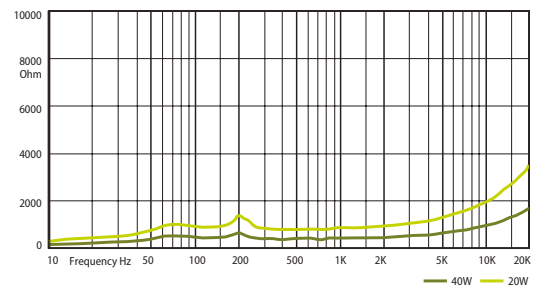

COLUMN LOUDSPEAKERS

COM Weatherproof Column Loudspeaker

COM aluminium body outdoor column loudspeakers.

COM 320 & COM 340

Wide frequency response and high sensitivity loudspeakers are used for speech and background music reproduction in large areas. Typical application: railway stations, subways, churches, factory buildings, warehouses and outdoor parking areas. Mainly designed for outdoor areas. **COM 320** utilises two 3" (76.2 mm) full range speakers and one 1" (25 mm) tweeter, **COM 340** has four 3" (76.2 mm) full range speakers and one 1" (25 mm) tweeter.

Technical Specifications	COM 320
Rated power	20 W
Transformer power taps	20 W - 10 W
Sensitivity	89 dB (1 W/1 m)
Maximum SPL	105 dB (Pmax/1 m) at 2440 Hz
Frequency response	135 Hz – 20 kHz
Dispersion at 1000 Hz	180° (H), 80° (V)
Protection	IP 66
Dimensions	370 mm × 110 mm x 97 mm
Driver dimensions	2 x 3" (76,2 mm) woofer, 1,5" (38,1 mm) tweeter
Weight	2,6 kg
Material	Aluminum
Colour	White (RAL 9016)

Technical Specifications	COM 340
Rated power	40 W
Transformer power taps	40 W - 20 W
Sensitivity	90 dB (1 W/1 m)
Maximum SPL	107 dB (Pmax/1 m) at 13335 Hz
Frequency response	135 Hz – 20 kHz
Dispersion at 1000 Hz	180° (H), 50° (V)
Protection	IP 66
Dimensions	545 mm × 110 mm x 97 mm
Driver dimensions	4 x 3" (76,2 mm) woofer, 1,5" (38,1 mm) tweeter
Weight	3,6 kg
Material	Aluminum
Colour	White (RAL 9016)



COM 320



HORIZONTAL / VERTICAL POLAR DIAGRAMS

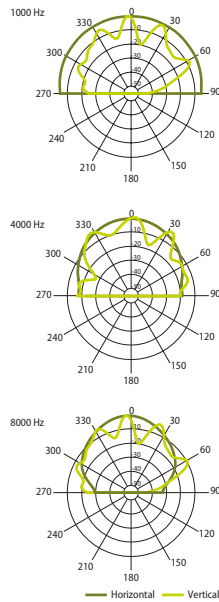

FREQUENCY RESPONSE

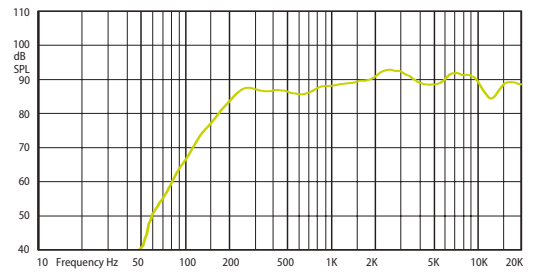

IMPEDANCE

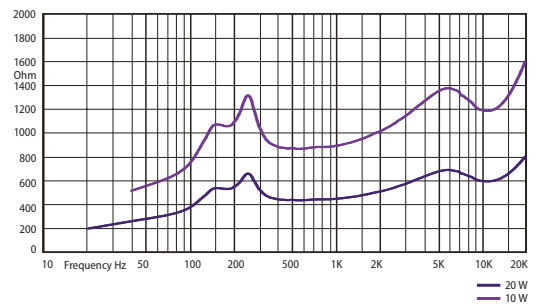

COM 340



HORIZONTAL / VERTICAL POLAR DIAGRAMS

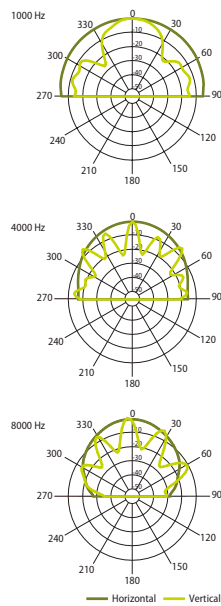

FREQUENCY RESPONSE

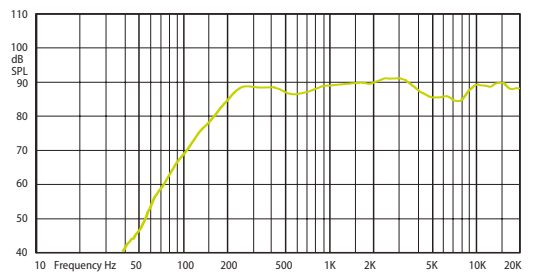

IMPEDANCE

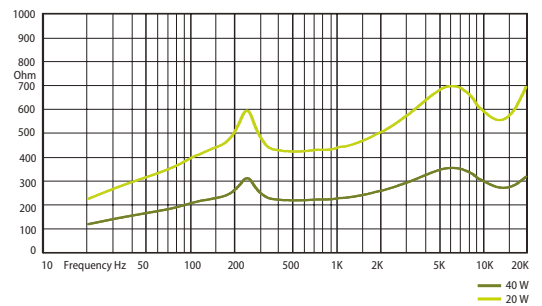

COLUMN LOUDSPEAKERS

COM Weatherproof Column Loudspeakers

COM aluminium body outdoor column loudspeakers

COM 420 & COM 440

Wide frequency response and high sensitivity loudspeakers are used for speech and background music reproduction in large areas. Typical application: railway stations, subways, churches, factory buildings, warehouses and outdoor parking areas. Mainly designed for use in outdoor areas. **COM 420** has built-in two 4" (101.2 mm) full range speakers and one 1" (25 mm) tweeter, **COM 440** uses four 4" (101.2 mm) full range speakers and one 1" (25 mm) tweeter.



Technical Specifications	COM 420	COM440
Rated power	20 W	40 W
Transformer power taps	20 W - 10 W	40 W - 20 W
Sensitivity	91 dB (1 W/1 m)	92 dB (1 W/1 m)
Maximum SPL	108 dB (Pmax/1 m) at 2900 Hz	110 dB (Pmax/1 m) at 8414
Frequency response	120 Hz – 20 kHz	120 Hz – 20 kHz
Dispersion at 1000 Hz	180° (H), 60° (V)	180° (H), 140° (V)
Protection	IP 66	IP 66
Dimensions	425 mm × 150 mm x 125 mm	655 mm × 150 mm x 125 mm
Driver dimensions	2 x 4" (101,2 mm) woofer, 1" (25,4 mm) tweeter	4 x 4" (76,2 mm) woofer, 1" (25,4 mm) tweeter
Weight	3,9 kg	5,9 kg
Material	Aluminum	Aluminum
Colour	White (RAL 9016)	White (RAL 9016)

COM 420

FREQUENCY RESPONSE

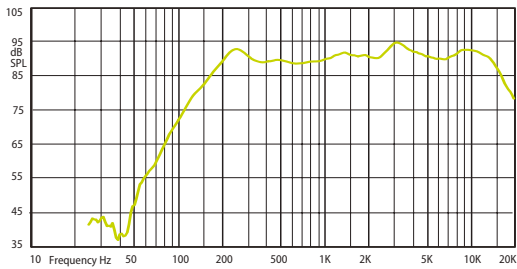

IMPEDANCE

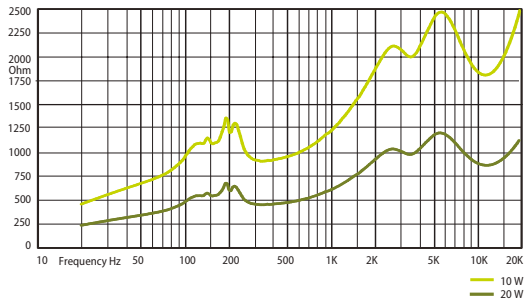

HORIZONTAL / VERTICAL POLAR DIAGRAMS

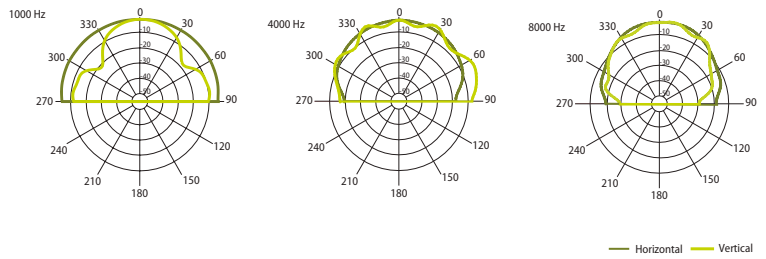

COM 440

FREQUENCY RESPONSE

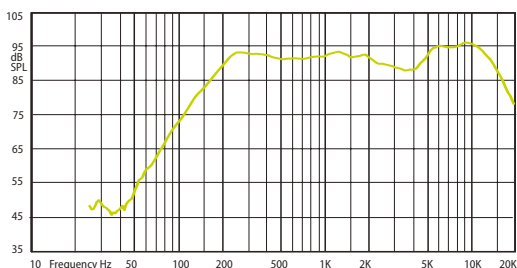

IMPEDANCE

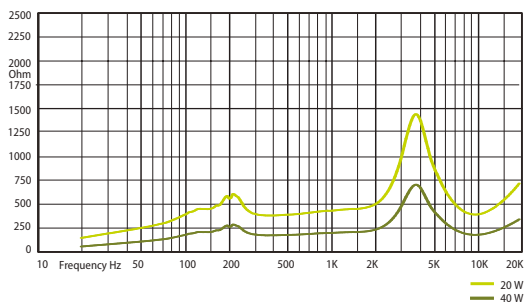

HORIZONTAL / VERTICAL POLAR DIAGRAMS

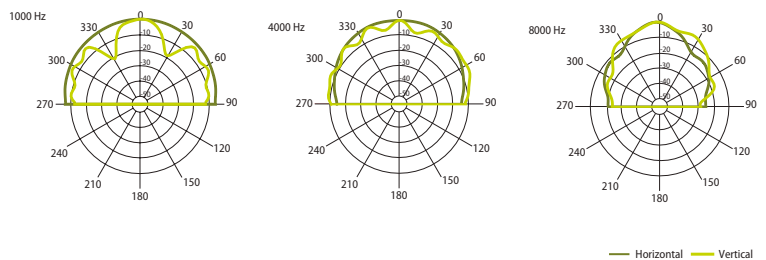

COLUMN LOUDSPEAKERS
COM SLIM Column Loudspeakers

Ultra slim aluminum body column loudspeakers

COM SLIM

Slim body loudspeakers, designed for use in the areas with high reverberation time, like churches, train stations or market halls. The special mounting bracket is designed for precise angle alignment after installation. The speakers have an elegant design for very neutral appearance in the sensitive interiors.

Technical Specifications	COM SLIM 50
Rated power	50 W
Transformer power taps	50 W - 25 W - 12,5 W - 20 Ω
Sensitivity	91 dB (1W/1m)
Maximum SPL	108 dB (Pmax / 1m)
Frequency response	180 Hz - 18 kHz
Dispersion at 1000 Hz	180° (H), 70° (V)
Protection	IP 55
Driver dimensions	10 x 2" (51 mm) woofer, 1 x 1" (25 mm) tweeter
Dimensions	802 mm x 75 mm x 69 mm
Weight	3,5 kg
Material	Aluminum
Colour	White (RAL 9016)

Technical Specifications	COM SLIM 30
Rated power	30 W
Transformer power taps	30 W - 15 W - 7,5 W - 8 Ω
Sensitivity	91 dB (1W/1m)
Maximum SPL	108 dB (Pmax / 1m) at 1995 Hz
Frequency response	180 Hz - 18 kHz
Dispersion at 1000 Hz	140° (H), 80° (V)
Protection	IP 55
Driver dimensions	4 x 2" (50 mm) woofer, 1 x 1" (25 mm) tweeter
Dimensions	405 mm x 75 mm x 69 mm
Weight	1,7 kg
Material	Aluminum
Colour	White (RAL 9016)



COM SLIM 30

FREQUENCY RESPONSE

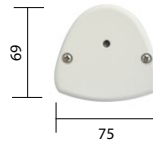
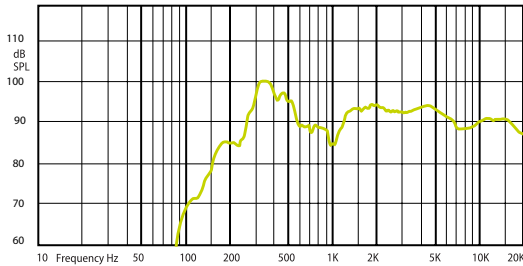

IMPEDANCE

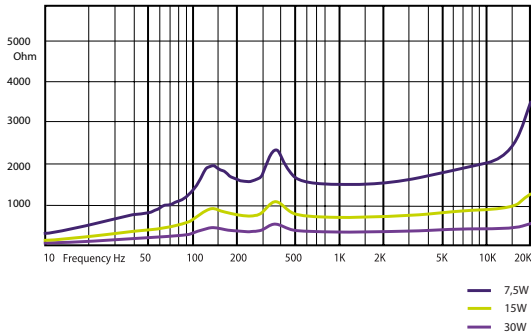

HORIZONTAL / VERTICAL POLAR DIAGRAMS

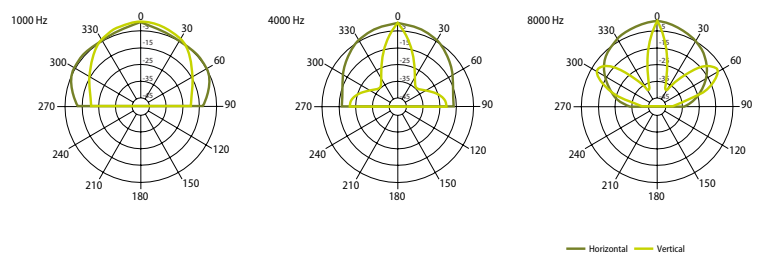

COM SLIM 50

FREQUENCY RESPONSE

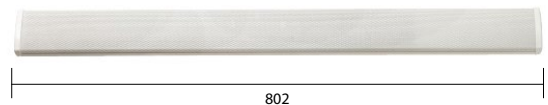
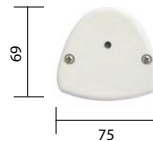
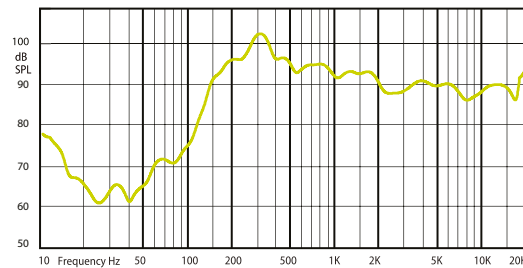

IMPEDANCE

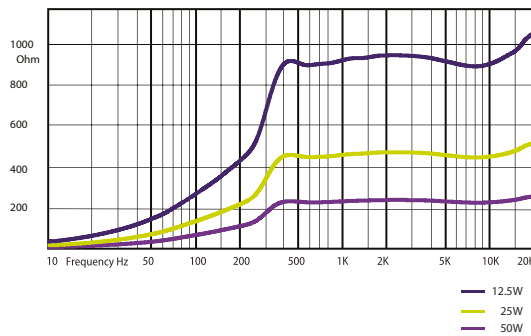

HORIZONTAL / VERTICAL POLAR DIAGRAMS

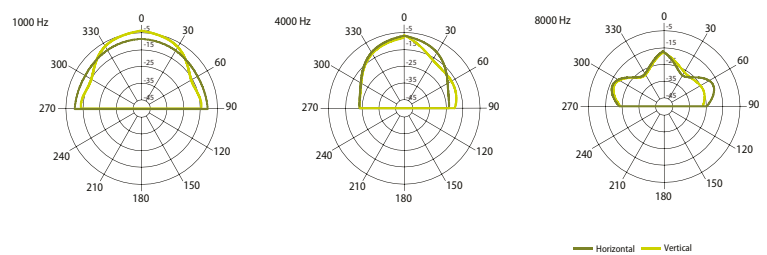



Gateways *of the* Globe



Simple. Reliable. Profitable.

AMC® BALTIC Series kr. 14A, LT-48397, Kaunas, Lithuania / (370 37) 308585 / www.amcpro.eu

HORN LOUDSPEAKERS

H Aluminium Body Horn Loudspeakers

H 15 aluminium body outdoor 15 W horn speaker with integrated 100 V line transformer.

H 15

Traditional design, robust construction and high SPL mean these horn speakers are ideal for use in large and medium-size public address and voice evacuation systems, where a high efficiency of speech announcements is required. Specific frequency bandwidth and high SPL makes them ideal for use in noisy environments



HORIZONTAL / VERTICAL POLAR DIAGRAMS

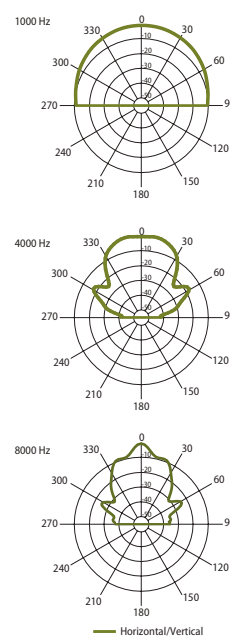

FREQUENCY RESPONSE

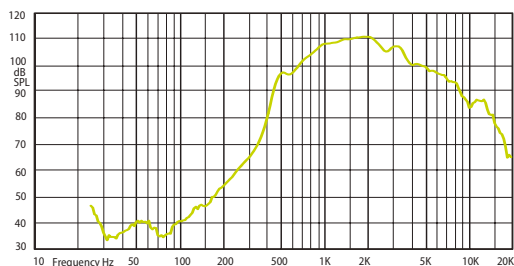

IMPEDANCE

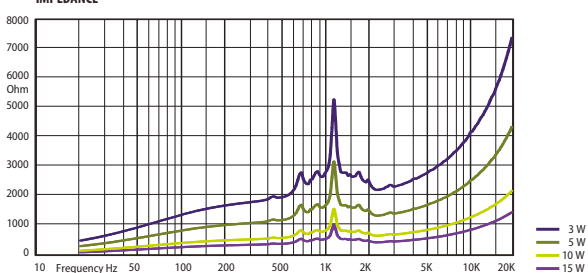

Technical Specifications	H 15
Rated power	15 W
Transformer power taps at 100 V	15 W - 10 W - 5 W - 3 W
Sensitivity	103 dB (1 W/ 1 m)
Maximum SPL	118 dB (Pmax / 1 m) at 1631 Hz
Frequency response	400 Hz – 8 kHz
Dispersion at 1000 Hz	140° conical
Driver dimensions	2" (50mm)
Protections	IP 65
Dimensions	ø200 mm x 241 mm
Weight	1,3 Kg
Material	Aluminum horn and U type bracket
Colour	White (RAL 9018)

HORN LOUDSPEAKERS

HQ Plastic Horn Loudspeakers

HQ - reliable and powerful outdoor horn loudspeaker.

HQ10, HQ15 & HQ30

Improved quality plastic horn speakers with extremely high SPL and a powerful middle range frequency response. Well suited for indoor and outdoor installation. For voice evacuation and paging systems. With U-mounting bracket.



Technical Specifications	HQ 10	HQ 15	HQ 30
Rated power	10 W	15 W	30 W
Transformer power taps	10 W - 5 W	15 W - 7,5 W	30 W - 15 W
Sensitivity	103 dB (1 W/1 m)	105 dB (1 W/1 m)	105 dB (1 W/1 m)
Maximum SPL	116 dB (Pmax/1 m) at 1412 Hz	117 dB (Pmax/1 m) at 1815 Hz	120 dB (Pmax/1 m) at 1249 Hz
Frequency response	500 Hz – 8 kHz	400 Hz – 5 kHz	400 Hz – 6 kHz
Dispersion at 1000 Hz	140° (H), 90° (V)	140° (H), 90° (V)	140° (H), 90° (V)
Protection	IP 65	IP 66	IP 66
Dimensions	190 mm × 180 mm x 130 mm	222 mm × 162 mm x 232 mm	285 mm × 280 mm x 205 mm
Weight	1,1 kg	1,4 kg	1,8 kg
Material	Plastic horn, U type steel bracket	ABS plastic, U type steel bracket	ABS plastic, U type steel bracket
Colour	White (RAL 9018)	White (RAL 9018)	White (RAL 9018)

HQ 10

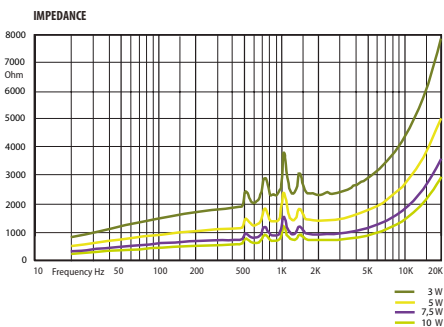
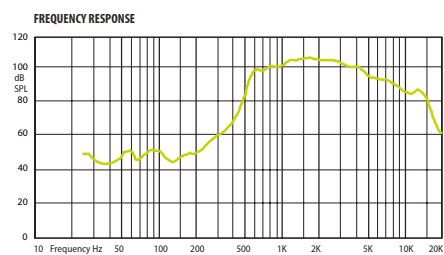

HORIZONTAL / VERTICAL POLAR DIAGRAMS

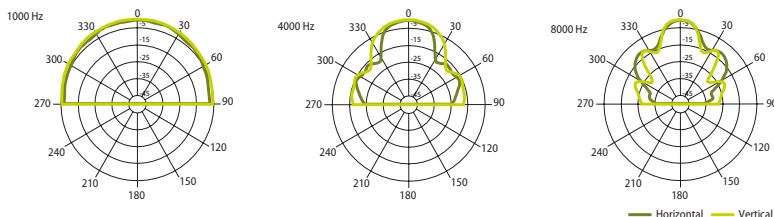

HQ 15

HORIZONTAL / VERTICAL POLAR DIAGRAMS

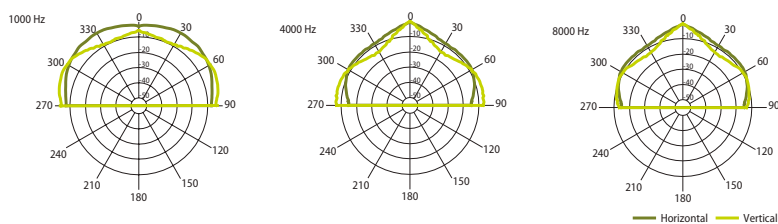

FREQUENCY RESPONSE

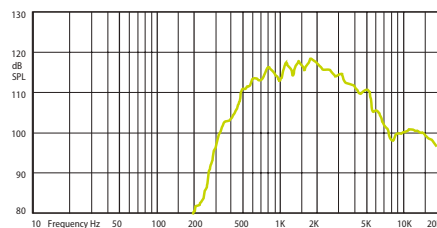

IMPEDANCE

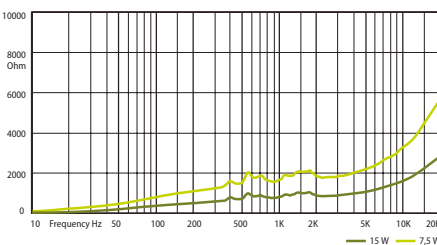

HQ 30

FREQUENCY RESPONSE

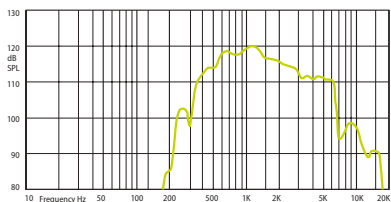

HORIZONTAL / VERTICAL POLAR DIAGRAMS

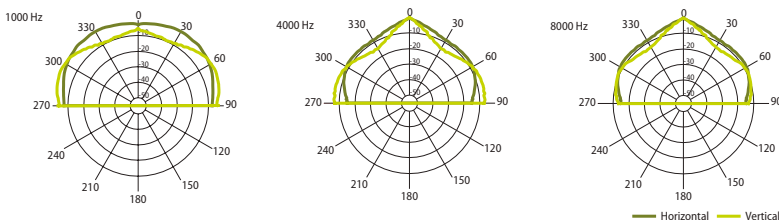

IMPEDANCE

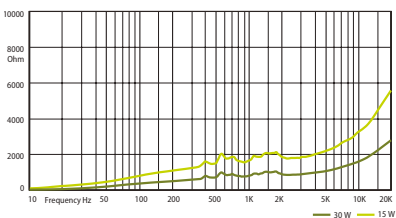

HORN LOUDSPEAKERS

MH Two-Way Plastic Horn Loudspeakers

Waterproof horn loudspeaker with extremely wide frequency response and high SPL level.

MH 50

Wide frequency response allows this speaker to be used for background music. Built-in 100V transformer with power taps and 8Ω input selection, grey colour body, U-mount included. For indoor and outdoor use, where background music is a priority.

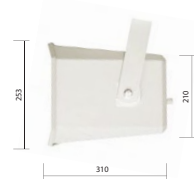

HORIZONTAL / VERTICAL POLAR DIAGRAMS

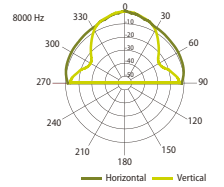
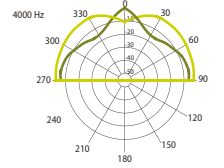
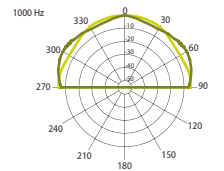

— Horizontal — Vertical

FREQUENCY RESPONSE

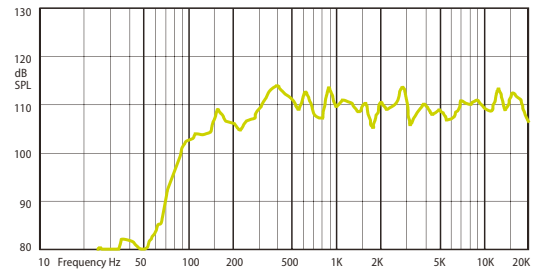

IMPEDANCE

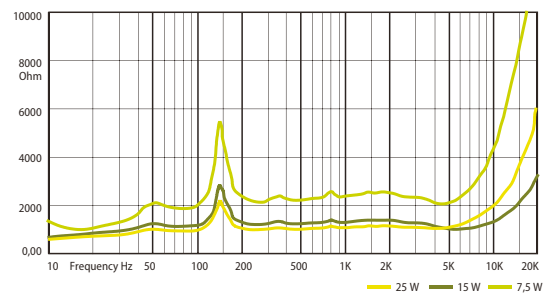

	MH 50
Rated power	50 W (8 Ω)
Transformer power taps	50 W - 25 W - 12,5 W - 8 Ω
Sensitivity	99 dB (1 W/1 m)
Maximum SPL	115 dB (Pmax/1 m) at 2715 Hz
Frequency response	90 Hz – 20 kHz
Dispersion at 1000 Hz	150° (H), 120° (V)
Protection	IP 55
Dimensions	363 mm × 253 mm x 310 mm
Weight	3,9 kg
Material	ABS plastic, U type aluminum bracket
Colour	Cold grey (RAL 7035)

HORN LOUDSPEAKERS

MHQ Two-Way Plastic Horn Loudspeakers

Music horn loudspeaker with wide frequency response and improved protection against water and dust.

MHQ 60X

2-way plastic music horn loudspeakers with high SPL and improved linearity. Engineered to provide the highest quality music and speech reproduction, where long throw in large areas is required.

MHQ is a reliable and powerful horn speaker with built-in 100V transformer with power taps.

HORIZONTAL / VERTICAL POLAR DIAGRAMS

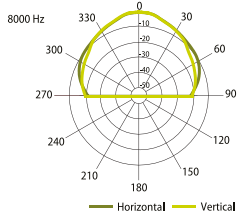
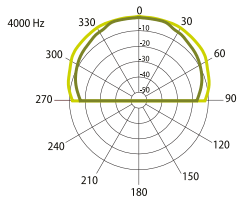
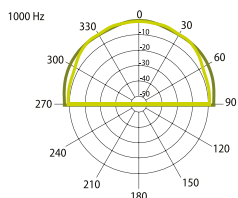

— Horizontal — Vertical

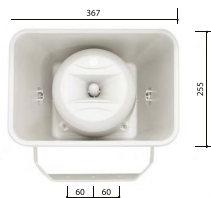

FREQUENCY RESPONSE

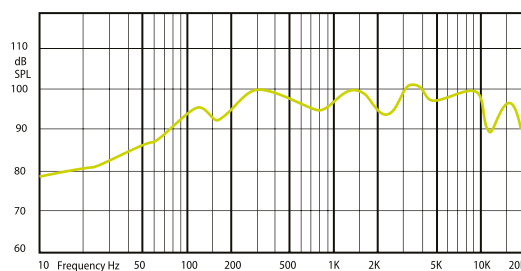

IMPEDANCE

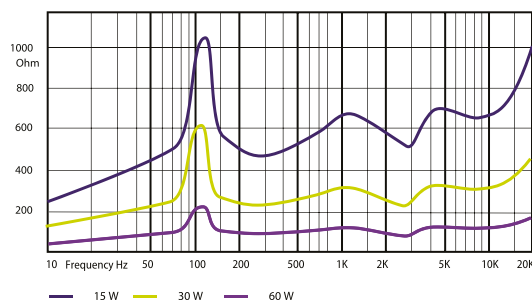

Technical Specifications	MHQ 60X
Rated power	60 W
Transformer power taps	60 W - 30 W - 15 W
Sensitivity	93 dB (1 W/1 m)
Maximum SPL	115 dB (Pmax/1 m) at 1496 Hz
Frequency response	98 Hz – 18 kHz
Dispersion at 1000 Hz	120° (H), 80° (V)
Protection	IP 66
Dimensions	367 mm x 255 mm x 293 mm
Weight	6,2 kg
Material	ABS plastic, U-type aluminum bracket
Colour	Light grey (RAL 7035)

POWERED CABINET LOUDSPEAKERS
POWER BOX Powered Systems

Powered small size speaker boxes for installed sound applications.

POWER BOX 51 & 61

Power Box 51 & 61 are two way loudspeaker systems, consisting of loudspeaker with built-in stereo amplifier and second non-powered loudspeaker ready to connect to the active one with Euroblock connector. High efficiency D-class power amplifier. U-brackets for mounting on walls or ceiling.



HORIZONTAL / VERTICAL POLAR DIAGRAMS

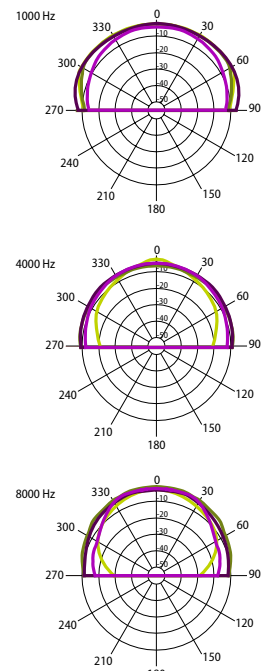

Power Box 51 — Horizontal — Vertical
 Power Box 61 — Horizontal — Vertical

FREQUENCY RESPONSE

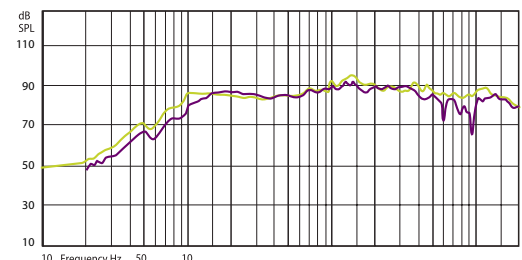

IMPEDANCE

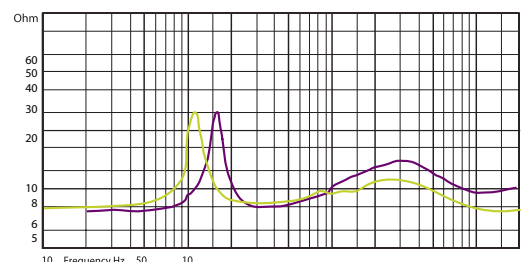

— Power Box 51 — Power Box 61

Technical Specifications	POWER BOX 61	POWER BOX 51
Rated power	2 x 30 W	2 x 20 W
Frequency response	80 Hz - 20 kHz	120 Hz - 20 kHz
Sensitivity	88 dB (1W / 1m)	
Maximum SPL	95 dB (Pmax/1m) at 1000 Hz	91 dB (Pmax/1m) at 1000 Hz
Input sensitivity	580 mV	300 mV
Dispersion 1000 Hz	120° (H), 140°(V)	130° (H), 150°(V)
Speakers size	6" woofer, 1" tweeter	5" woofer, 1" tweeter
Tone	Bass ± 12 dB, Treble ± 12 dB	
Dimensions	302 mm x 196 mm x 193 mm	252 mm x 163 mm x 163 mm
Weight	Active - 5 kg, passive - 3,2 kg	Active - 4 kg, passive - 2,2 kg
Material	Housing - plastic, grill - aluminum and U-bracket - steel	
Colour	White RAL 9016, Black RAL 9017	

POWERED CABINET LOUDSPEAKERS
POWER BOX 5HP Powered Systems

Powered small size speaker boxes for installed sound applications.

POWER BOX 5HP

Power Box 5HP is high performance active speaker system with the amplifier built into the main speaker, while other one loudspeaker is passive and connected as a slave unit. For production of these speakers have been used high quality materials. Bass, treble and volume control with direct access on the loudspeakers rear. U-bracket for mounting on the wall and IR remote control are included. This system is a good choice for small installations in classrooms and for use in communication and paging systems.



HORIZONTAL / VERTICAL POLAR DIAGRAMS

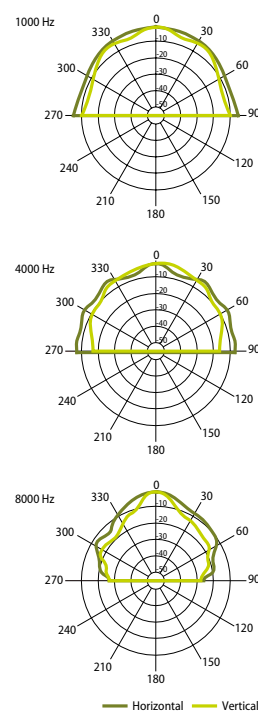

FREQUENCY RESPONSE

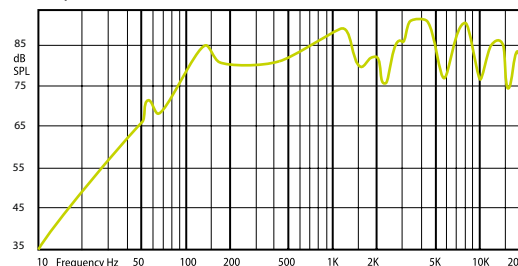

IMPEDANCE

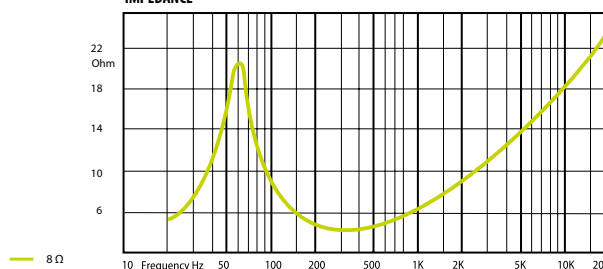

Technical Specifications	POWER BOX 5HP
Rated power	2 x 20 W
Equalization	2 bands EQ \pm 14 dB
Sensitivity	85 dB (1W / 1m)
Maximum SPL	98 dB (Pmax / 1m) at 4097 Hz
Frequency response	115 Hz - 20 kHz
Input sensitivity	-3 dBu
Speakers impedance	6 Ω
Dispersion 1000 Hz	120° (H), 100°(V)
Driver dimensions	5" (127 mm) woofer, 1" (25 mm) tweeter
Dimensions	230 mm x 145 mm x 145 mm
Weight	3,45 kg
Material	Housing - plastic, U type mounting bracket - steel
Colour	White (RAL 9003)

POWERED CABINET LOUSPEAKERS

POWER BOX 5 Powered Systems

Powered small size speaker boxes for installed sound applications.

POWER BOX 5

Power Box 5 is a set of 2 loudspeakers: a powered loudspeaker with a built-in stereo amplifier and a non-powered loudspeaker ready to be connected to the powered loudspeaker. 5.25" woofer and 1" tweeter, tone control, stereo/mono switch. U-mounting bracket is included in the set. Perfect choice for small installations in a classroom, or for communication and paging systems. Available in two colours: RAL9016 (white) and RAL9017 (black).



HORIZONTAL / VERTICAL POLAR DIAGRAMS

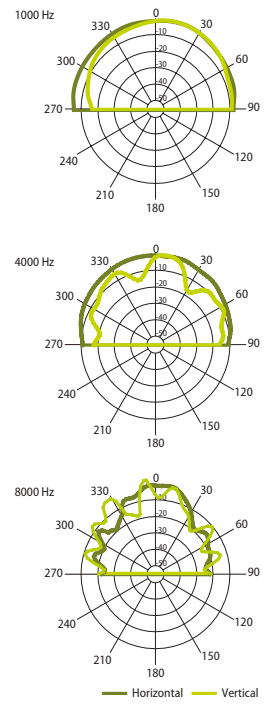

FREQUENCY RESPONSE

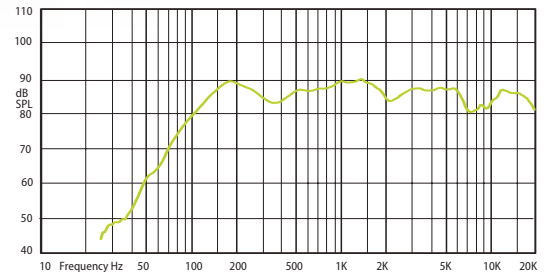

IMPEDANCE

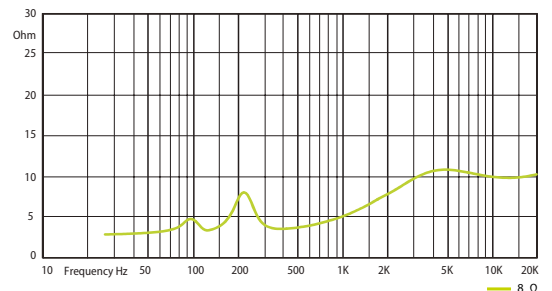

Technical Specifications	POWER BOX 5
Rated power	2 x 20 W
Equalization	2 bands EQ \pm 14 dB
Sensitivity	87 dB (1 W/1 m)
Maximum SPL	104 dB (Pmax/1 m) at 1258 Hz
Amplifier frequency response	80 Hz – 20 kHz
Input sensitivity	-7 dBu
Speakers impedance	8 Ω
Dispersion	160° (H), 120° (V)
Driver dimensions	5,25" (133 mm) woofer, 1" (24 mm) tweeter
Dimensions	240 mm x 178 mm x 170 mm
Weight	6 kg
Material	Housing - plastic, grill and U-bracket - steel
Colour	White (RAL 916) Black (RAL 9017)

SOUND PROJECTORS

SPM HP High Performance Sound Projectors

SPM HP – aluminium body outdoor sound projectors with integrated 100 V line transformer.

SPM 20HP

Featuring a robust and solid aluminium body construction, full range speaker and a built-in 100 V line transformer with power taps. IP66 rated for use in heavy weather conditions. This sound projector is the ideal choice for outdoor applications, where background music is a priority.

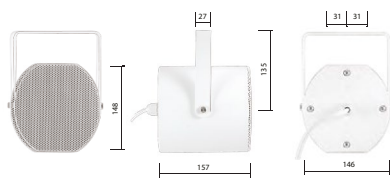

HORIZONTAL / VERTICAL POLAR DIAGRAMS

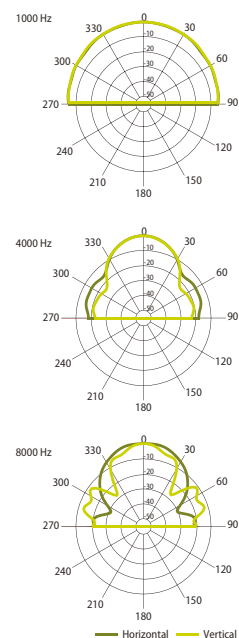

FREQUENCY RESPONSE

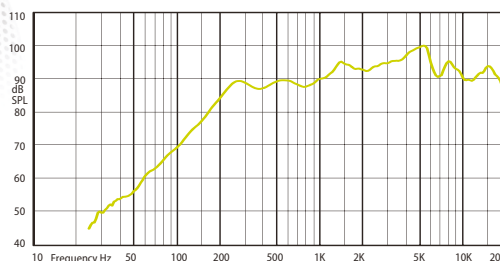

IMPEDANCE

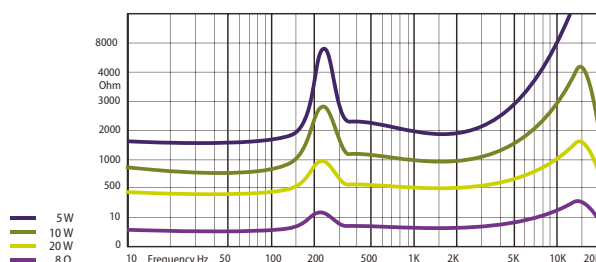

	SPM 20HP
Rated power	20 W
Transformer power taps	20 W - 10 W - 5 W - 8 Ω
Sensitivity	94 dB (1 W/1 m)
Maximum SPL	109 dB (Pmax/1 m) at 5158 Hz
Frequency response	130 Hz – 20 kHz
Dispersion at 1000 Hz	180° conical
Protection	IP 66
Dimensions	146 mm × 148 mm × 157 mm
Driver dimensions	5" (127 mm)
Weight	3,6 kg
Material	Aluminum
Colour	White (RAL 9016)

SOUND PROJECTORS

SP Plastic Body Sound Projectors

Advanced design sound projectors with built-in 100V line transformer.

SP 10

SP 10 is a plastic bodied sound projector used to provide high quality sound reproduction for music and speech, IP55 rated for heavy environmental conditions. For use in supermarkets, warehouses, factory buildings, railway stations, car parking areas and pools, wherever clear, high-quality directional sound is required.



HORIZONTAL / VERTICAL POLAR DIAGRAMS

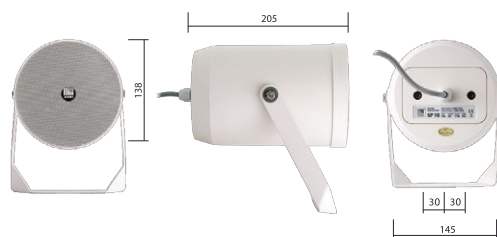
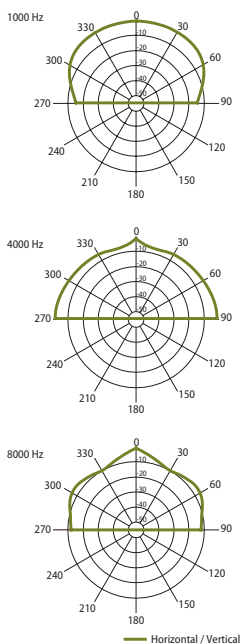

FREQUENCY RESPONSE

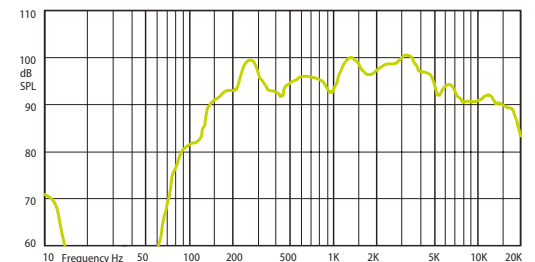

IMPEDANCE

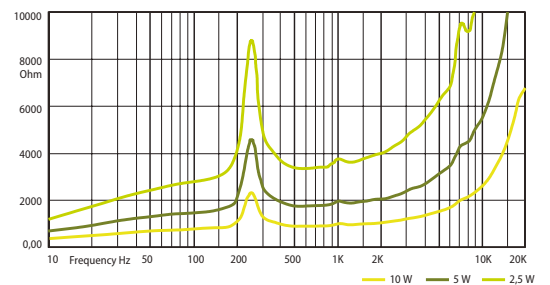

Technical Specifications	SP 10
Rated power	10 W
Transformer power taps	10 W - 5 W - 2,5 W
Sensitivity	91 dB (1 W/1 m)
Maximum SPL	101 dB (Pmax/1 m) at 3227 Hz
Frequency response	130 Hz – 15 kHz
Dispersion at 1000 Hz	130° conical
Protection	IP 55
Dimensions	ø 138 mm × 205 mm
Weight	1,6 kg
Material	ABC plastic, stainless U bracket
Colour	White (RAL 9016), black (RAL 9017)

SOUND PROJECTORS

SPMB Bidirectional Aluminum Sound Projectors

SPMB bidirectional sound projector with integrated 100V line transformer.

SPMB 10

Aluminium body, 10W power sound projector loudspeaker with ceiling mounting bracket. 130Hz – 15kHz frequency response. Designed for use in music and speech reproduction applications. SPMB 10 has two built-in 5”(127 mm) full range speakers.



FREQUENCY RESPONSE

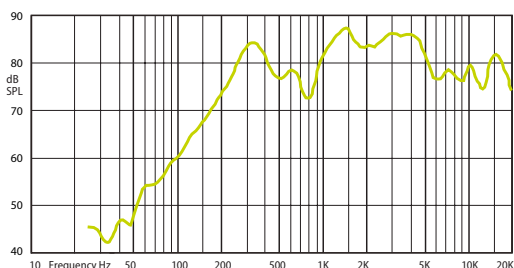

IMPEDANCE

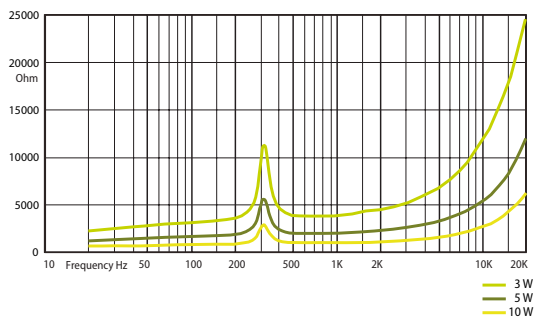

HORIZONTAL / VERTICAL POLAR DIAGRAMS

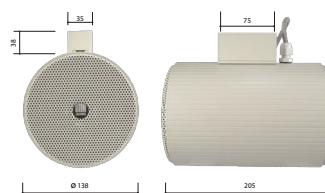
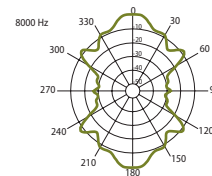
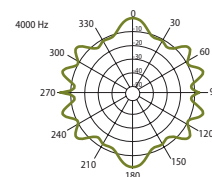
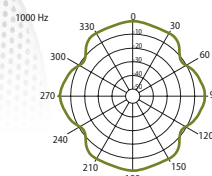

Technical Specifications	SPMB 10
Rated power	10 W
Transformer power taps at 100 V	10 W - 5 W - 3 W
Sensitivity	88 dB (1 W/1 m)
Maximum SPL	101 dB (Pmax/1 m) at 1223 Hz
Frequency response	180 Hz – 18 kHz
Dispersion at 1000 Hz	90° conical
Driver dimensions	5" (127mm)
Protections	IP 55
Dimensions	ø 138 mm x 205 mm
Weight	2,7 Kg
Material	Aluminum
Colour	White (RAL 9018)

SOUND PROJECTORS

SPM Aluminum Sound Projectors

SPM aluminum body sound projector for outdoor use with integrated 100V line transformer.

SPM 20

Robust and solid aluminium body construction with built-in full range speaker, 100V transformer with power taps, IP55 rated. This sound projector is ideal for use in supermarkets, warehouses, factory buildings, railway stations, car parking areas, petrol stations and pools. Ideal for outdoor use.

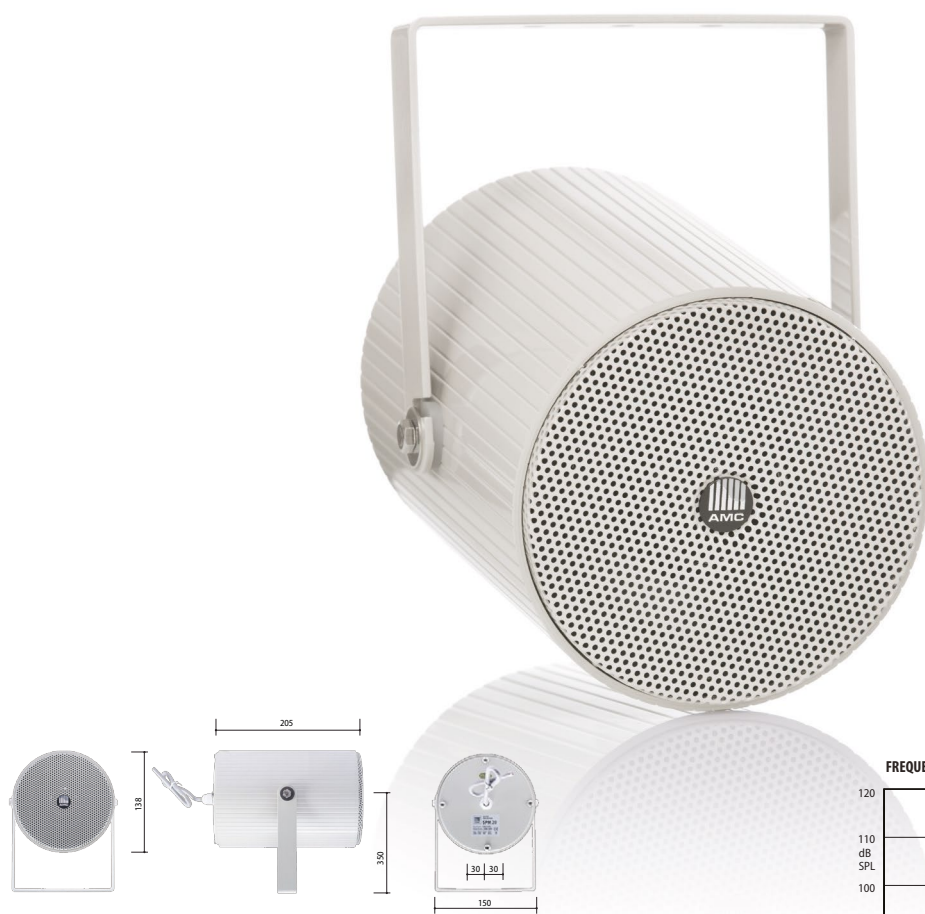

HORIZONTAL / VERTICAL POLAR DIAGRAMS

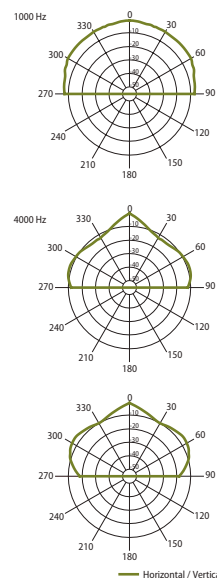

FREQUENCY RESPONSE

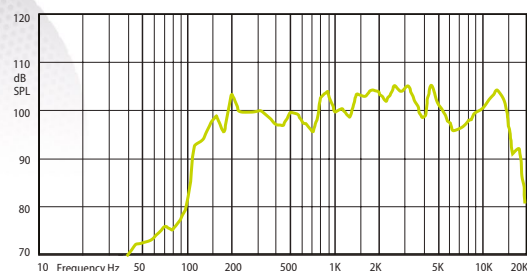

IMPEDANCE

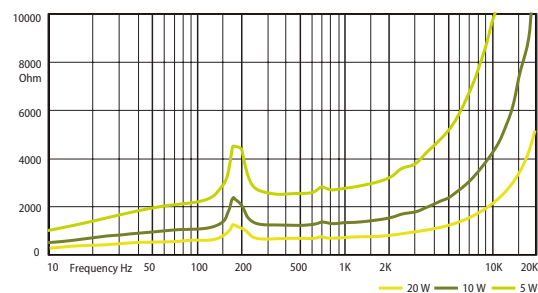

Technical Specifications	SPM 20
Rated power	20 W
Transformer power taps	20 W - 10 W - 5 W
Sensitivity	92 dB (1 W/1 m)
Maximum SPL	105 dB (Pmax/1 m) at 3135 Hz
Frequency response	130 Hz – 15 kHz
Dispersion at 1000 Hz	140° conical
Protection	IP 55
Dimensions	ø 138 mm × 205 mm
Weight	2,2 kg
Material	Aluminum, stainless U bracket
Colour	White papyrus (RAL 9018)



Forums *of* Funk



Simple. Reliable. Profitable.

AMC® BALTIC Neries kr. 14A, LT-48397, Kaunas, Lithuania / (370 37) 308585 / www.amcpro.eu

SPHERICAL LOUDSPEAKERS

SL Plastic Spherical Loudspeakers

SL modern and stylish apherical loudspeakers with built-in 100 V line transformer.

SL 20M

SL 20M – omni-directional speaker device for applications that require uniform sound distribution. Unique and simple design for modern interiors. Excellent sound dispersion, smooth frequency response and carefully controlled speaker performance to use in difficult acoustic environments. ideal for rooms with high ceilings.

For additional safety, a wire rope is integrated into the hanging cable.



HORIZONTAL / VERTICAL POLAR DIAGRAMS

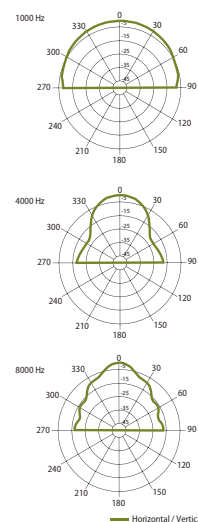

FREQUENCY RESPONSE

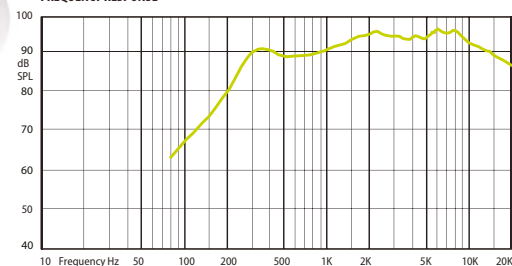

IMPEDANCE

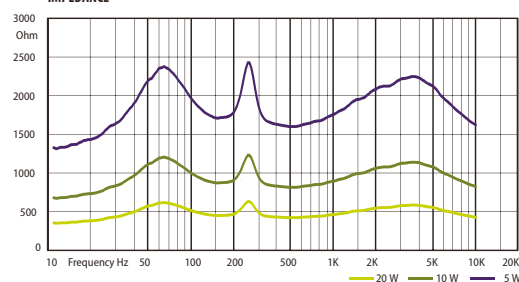

Technical Specifications	SL 20M
Rated power	20 W
Transformer power taps	20 W - 10 W - 5 W
Sensitivity	93 dB (1 W/1 m)
Maximum SPL	112 dB (Pmax/1 m) at 5415 Hz
Frequency response	180 Hz – 20 kHz
Dispersion at 1000 Hz	160° conical
Driver dimensions	6" (158 mm) woofer × 1" (25 mm) tweeter
Dimensions	ø 210 mm x 2000 mm
Weight	1,7 kg
Material	ABS plastic housing, grill - metal
Colour	White (RAL 9016), Black (RAL 9017), Chrome inserts



SPHERICAL LOUDSPEAKERS

SL Plastic Spherical Loudspeakers

SL modern and stylish apherical loudspeakers with built-in 100 V line transformer.

SL 30

SL 30 – a plastic 30 W spherical loudspeaker for background music and speech reproduction in large areas with high ceilings. Coaxial 6.5" (165 mm) speaker with built-in 100 V transformer with power selector and 8 Ω input. Wide frequency response, 160° conical sound dispersion. For additional safety, a wire rope is integrated into the hanging cable. Available in two colors: White (RAL 9016) and Black (9017).

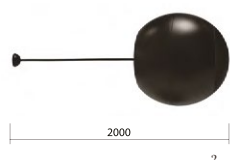

HORIZONTAL / VERTICAL POLAR DIAGRAMS

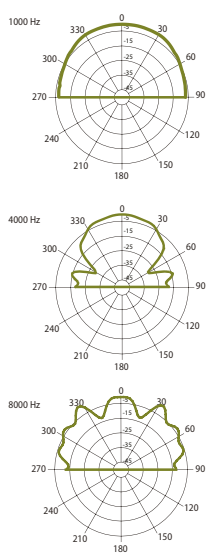

FREQUENCY RESPONSE

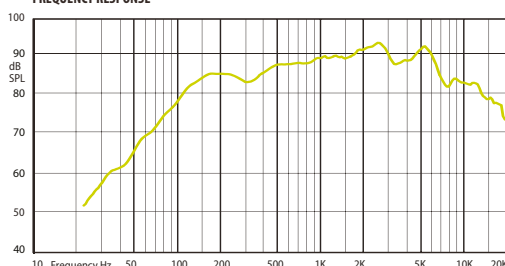

IMPEDANCE

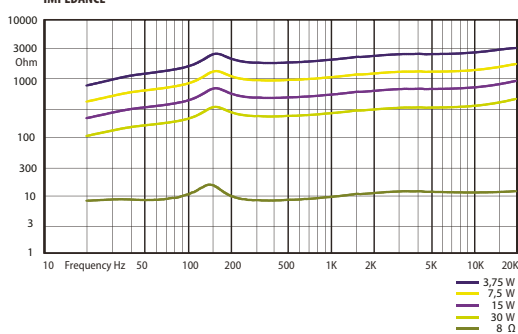

Technical Specifications	SL 30
Rated power	30 W (8 Ω)
Transformer power taps	30 W - 15 W - 7,5 W - 3,75 W
Sensitivity	89 dB (1 W/1 m)
Maximum SPL	108 dB (Pmax/1 m) at 2511 Hz
Frequency response	100 Hz - 20 kHz
Dispersion at 1000 Hz	160° conical
Driver dimensions	6,5" (165 mm) woofer x 1" (24 mm) tweeter
Dimensions	∅ 275 mm x 2000 mm
Weight	3 kg
Material	ABS plastic housing, grill - metal
Colour	White (RAL 9016), Black (RAL 9017)

SUBWOOFERS

SUB 100V Passive Subwoofers

Passive subwoofers with built-in 100V line transformer.

SUB 100V

SUB 100V passive subwoofer for 100V loudspeaker systems. Designed for easy mounting on flat surfaces: walls or ceilings.

Built-in high quality 100V transformer with input power selection allows directly connection to 100V loudspeaker lines.

Wooden cabinet with 8" woofer, low pass filter, 100V line power selector and low impedance input. SUB 100V sharply increase low frequency performance in background music systems.



HORIZONTAL / VERTICAL POLAR DIAGRAMS

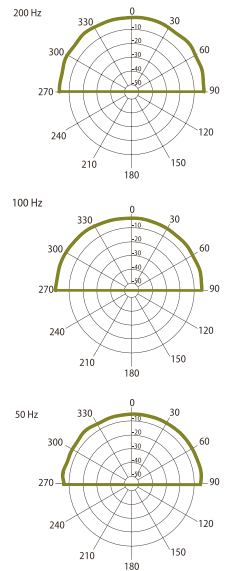

FREQUENCY RESPONSE

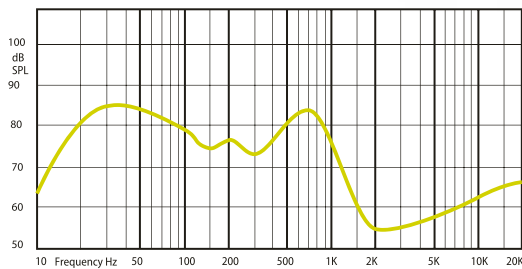

IMPEDANCE

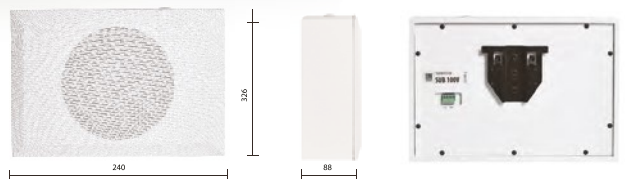
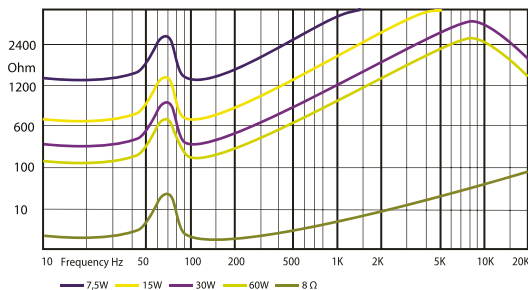

Technical Specifications	SUB 100V
Rated power	60 W
Transformer power taps	60 W - 30 W - 15 W - 7,5 W - 4 Ω
Sensitivity	82 dB (1W / 1m)
Maximum SPL	100 dB (Pmax / 1m) at 80 Hz
Frequency response	40 Hz - 1 kHz
Dispersion 100 Hz	180° conical
Driver dimensions	8" (205 mm)
Dimensions	326 mm x 240 mm x 88 mm
Weight	4,9 kg
Mounting	Steel bracket for mounting on the wall or ceiling
Colour	White (RAL 9019)

SUBWOOFERS

SUB Powered Subwoofers

SUB powered subwoofers for extra low frequency sound reproduction.

SUB 2

200W active subwoofer with front mounted high quality 10" glass aramid composite woofer. Strong bass output with 90 dB sensitivity. Small size and strong bass output will complement any installation where extra low frequencies are required.



HORIZONTAL / VERTICAL POLAR DIAGRAMS

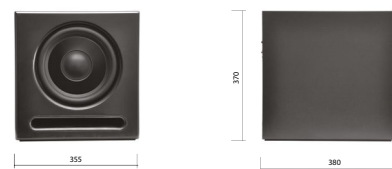
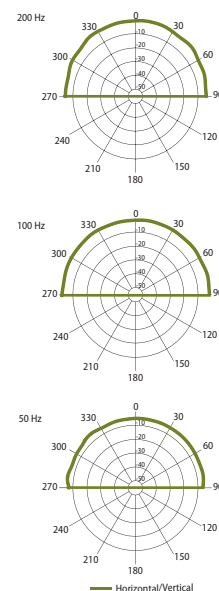

Technical Specifications	SUB 2
Rated power	200 W
Frequency response	20 Hz - 130 Hz
Low pass filter	50 Hz - 130 Hz
Maximum SPL	120 dB
Dispersion at 100 Hz	180° conical
Driver dimensions	10" (254mm) woofer
Input gain control	- 6 dBu - +3 dBu
Inputs	Stereo RCA, balanced stereo 6,3 mm TRS JACK, balanced stereo XLR
Dimensions	355 mm x 380 mm x 370 mm
Weight	12 kg
Material	Painted MDF
Colour	Black (RAL 9017)

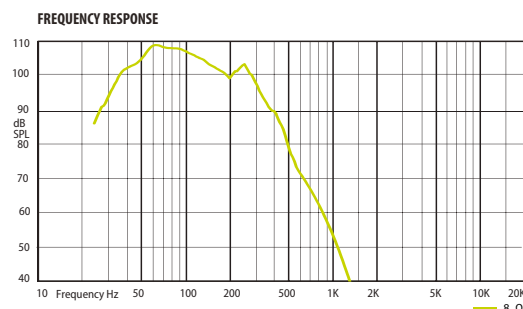

SPEAKER CABLE & CONNECTORS

Flame-retardant and oxygen-free speaker cable

OFCFR are double-shielded oxygen-free speaker cables with flame-retardant PVC insulator.

OFCFR 2x0.82 & OFCFR 2x1.5

Cables for voice evacuation and public address systems, available in two colours: Orange & Grey

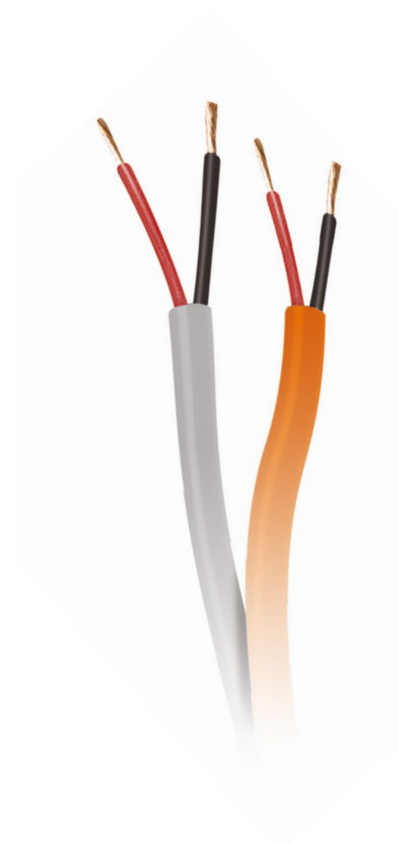

Technical Specifications	18 AWG	16 AWG
Size	2 x 0,82 mm ²	2 x 1,5 mm ²
Conductor number	2	2
Conductor material	OFC	OFC
Insulator material	PVC	PVC
Spool	100 m	100 m
Elementary wire conductor	19/0,25 mm	19/0,30 mm
Conductor resistance at 20° C	0,0187 Ω/m	0,0134 Ω/m
Capacitance	68,3 pF/m	95 pF/m
Colour	Orange or grey	Orange or grey

ACCESSORIES

TCB Table Connection Box

Anodized aluminum cable box.

TCB 2

Table top mount box for AV cable installation in conference, board rooms or auditoriums. The TCB 2 box has several cable openings for AV cable runs and 2 power plugs. Cables are easy accessible and hidden if not in use.

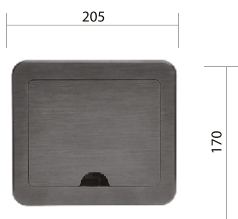

Technical Specifications	TCB 2
AC power socket	2 x 16 A, Euro shuko ~250 V, 3 pole
Power entry connector	ICE C 14 fused socket, 10 A ~250 V
Pass through cable slot	2 x Ø 12,5 mm, 3 x Ø 9 mm, 1 x Ø 6,5 mm
Installation requirement	Table cut out
Mounting accessories	2 x special screws
Dimensions	200 mm x 170 mm x 130 mm
Weight	2 kg
Material	Steel with anodized aluminum top
Colour	Black (RAL 9017)

Balanced audio cables, connectors and ceramic terminal blocks.

AUDIO CABLES & CONNECTORS

High quality screened audio cables and cable assemblies. Amphenol connectors and Taskers cables.

MK XLR Assembled Audio Cable

Balanced audio cable with AX3M and AX3F Amphenol connectors.



MK XLR/KL Assembled Audio Cable

Balanced audio cable with AX3M and TRS Amphenol connectors.



Product Name	MK XLR/KL	MK XLR
Type of cable	Shielded audio cable	Shielded audio cable
Connectors	Amphenol AX3M & TRS	Amphenol AX3M & AX3F
Cable specification	Tasker TSK1033	Tasker C112
Length	1.5m, 3m and 5m	1.5m, 3m and 5m
Weight	100g, 180g and 230g	150g, 230g and 350g
Colour	Blue	Blue

Product Name	XLR Connectors
Models	AX3M, AX3F
Gender	Male, Female
PIN number	3
Max wire size	2,5 mm ²
Wiring	Solder contacts
Weight	31g, 37g

Ceramic Terminal Blocks

High temperature resistant ceramic terminal blocks

Product Name	Ceramic Terminal Blocks
No. of poles	3
Max. voltage	600V
Max. current	24A
Max. wire size	2 x 1.5 mm ² or 1 x 2.5 mm ²
Dimensions	34 mm x 18 mm x 16 mm
Weight	22g



XLR Connectors

Cable connectors.



Mounting Brackets, Boxes & Transformers

Mounting brackets, 100V line transformers & single gang boxes for VC volume controls

MOUNTING HARDWARE

MB1 wall mount bracket

MB1 mounting bracket for COM SLIM loudspeakers ►

Product Name	Wall mount bracket for COM SLIM loudspeaker
Model	MB1
Dimensions	82 mm x 82 mm x 100 mm
Mounting hole diameter	Ø6 mm
Material	Steel
Weight	0,2 kg
Colour	White (RAL 9016)



MB6 Cluster Assemblies

MB6 - Mounting assemblies for 6 pieces

VIVA3 302 / VIVA3 502 speakers hung from ceilings ▼



Product Name	Cluster Assembly	Cluster Assembly
Model	MB6 for VIVA3 302 Cluster Mount	MB6 for VIVA3 502 Cluster Mount
Dimensions	Ø365 mm x 110 mm	Ø485 mm x 117 mm
Mounting hole diameter	Ø10 mm	Ø10 mm
Material	Steel	Steel
Weight	2,5 kg	3,10 kg
Colour	White (RAL 9016)	White (RAL 9016)

pBOX Plastic Box for Volume Control Units

pBox - plastic surface mount box for VC and WC iMIX volume control units ▼

Product Name	mBox
Material	Plastic
External dimensions	85 mm x 50 mm x 85 mm
Internal dimensions	80 mm x 47 mm x 80 mm
Weight	109 g
Colour	White (RAL 9016)
Mounting type	Surface mount



iBox Single Gang Box for Volume Control Units

iBox single gang box for VC and WC iMIX volume control flush mount ▶

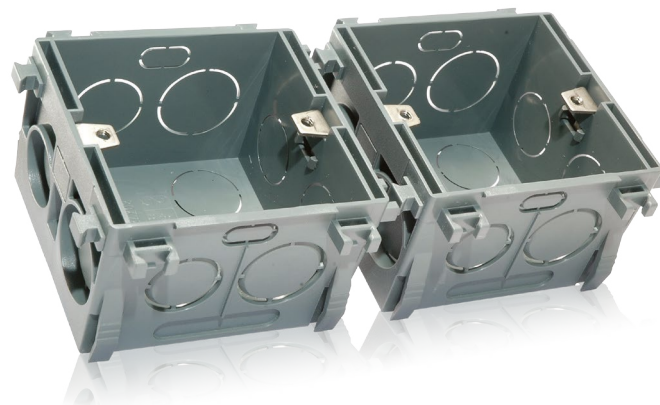

Product Name	iBox
Material	Plastic
External Dimensions	80 mm x 78 mm x 52 mm
Internal Dimensions	68 mm x 70 mm x 50 mm
Weight	60 g
Colour	Black (RAL9017)
Mounting type	Flush mount

100 V Line Transformers

Transformers for 100 V speaker lines with secondary winding for 8Ω speakers.

Speaker line maximum load - 10W, 20W, 30W, 50W ▼

Technical Specifications	TR-10	TR-20	TR-30	TR-50
Power	10W	20W	30W	50W
Transformer power taps	10 W - 5 W - 2,5 W - 1,25 W	20 W - 10 W - 5 W - 2,5 W	30W	50W
Load for secondary winding	8Ω	8Ω	8Ω	8Ω
Weight	0,3 kg	0,3 kg	0,3 kg	0,6 kg
Dimensions	50 mm x 43 mm x 40 mm	50 mm x 43 mm x 43 mm	50 mm x 43 mm x 41 mm	60 mm x 50 mm x 52 mm
Cable length	200 m	200 mm	190 mm	200 mm

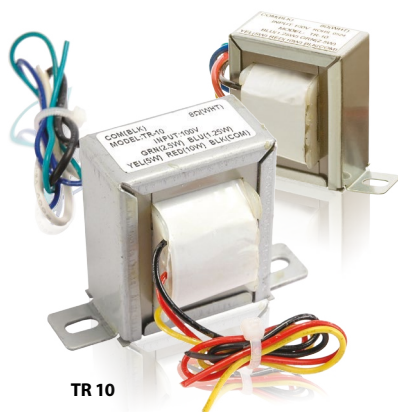

TR 10



TR 20



TR 30



TR 50



LITEXPO

EXHIBITION CENTRE

Where the pulse of public life is best felt and its changes are quickest to be noticed.

The Lithuanian Exhibition and Congress Centre LITEXPO is a unique place where the pulse of public life is best felt and its changes are quickest to be noticed. It is a place that is always open for business development, search for new markets, business contacts and boldest ideas. LITEXPO complex consists of 5 exhibition halls, where public address system is equipped with AMC loudspeakers: PC5T, PC8T and MC5T ceiling loudspeakers, iPlay 6, iPlay 5WT and VIVA3-502

cabinet loudspeakers, horn speakers and other equipment. The total exhibiting area of which amounts to 17.6K m², and external grounds that cover 15.1K m². All in all, total exhibiting area reaches 32.7K m². Currently LITEXPO is the largest exhibition and convention centre in the Baltic States by the number of events it organizes and the income index, as well as by the exposition area supplied with up-to-date equipment.

ELECTRONICS INDEX

DIGITAL SIGNAL PROCESSING

DSP 24 Digital Signal Processor	82
OCTO Digital Signal Processor	83

INSTALLATION AMPLIFIERS

iA 240X, iA 360X & iA 480X Installation Amplifiers.....	84-85
iA 2X250 & iA 4X125 Installation Amplifiers.....	86

MIXING AMPLIFIERS

DMPA 60, DMPA 120 & DMPA 240 Media Player Amplifiers.....	88-89
iCOMC 2X20 Communication Amplifier	90
MA 30X Mixing Amplifier	91
MA 60, MA 120 & MA 240 Mixing Amplifiers	92-93
MA 21 Multichannel Mixing Amplifier	95
MMA120X & MMA240X 5 Zone Mixing Amplifiers.....	96
FM/AM/USB/SD Module for MMA Amplifiers	97
Page Station 5X paging microphone for MMA Amplifiers	97
MPA 30 Media Player Amplifier	98
MPA 60 Media Player Amplifier	99

MIXING PREAMPLIFIERS

iMIX 5 Stereo Mixing Preampfier	100
MIC iMIX Paging Microphone for iMIX 5	101
WC iMIX Touch Sensitive Volume Control for iMIX 5	101
iMIX 2 Two Zone Mixing Preampfier	102
iMIX 63 Stereo Mixing Preampfier.....	103

MUSIC PLAYERS

MP 22 Double Media Player with Paging	105
DAB RADIO Digital and FM Radio Player	106
LIVE RADIO Internet Radio Player	107
MP 01 Music Player.....	108
MP 02 Music Player.....	109
MP 02B Music Player With Bluetooth	110
MP 03 Music Player.....	111
MP 05 Music Player and Recorder	112
MP 06S Music Player with Speed Control	113

POWER AMPLIFIERS

A100 Power Amplifiers	114
A200 Power Amplifiers	115



DIGITAL SIGNAL PROCESSING
DSP 24 Digital Signal Processor

Full matrix 2X4 digital signal processor.

DSP 24

DSP 24 – 2 input and 4 output DSP for line level audio signal processing and routing. Intuitive operation software gives easily understandable access to mandatory parameters of any audio system driven by DSP24. Device perfectly fits small size audio installations to mix and rout audio, split frequencies for two way audio systems, adjust timing, add noise gate, set EQ or add audio limiter. Ideal for bars, small disco halls and high quality background music.



Technical Specifications	DSP 24
Power supply	~ 230 V / 50 Hz
Power consumption	5 VA
Input / output connector	Balanced XLR
Input impedance	10 kΩ
Output impedance	1 kΩ
Maximum output level	+8 dBu
Maximum gain	-60 dBu
Frequency response	20 Hz - 20 kHz
Distortion	< 0.01% (0 dBu / 1 kHz)
Sampling rate	48 kHz
AD/DA converter	24 bit
Dynamic range	100 dBu
Supported OS	Windows XP / WIN7 / WIN8 / WIN10
Weight	1,1 kg
Dimensions	242 mm x 112 mm x 44 mm

DIGITAL SIGNAL PROCESSING

OCTO Digital Signal Processor

Full matrix 8X8 digital signal processor.

OCTO

OCTO – 8 input and 8 output full matrix DSP platform for microphone and line level audio processing. High performance 48 kHz sampling rate 24 bit AD/DA converters. Processor configuration can be done in real time with computer via Ethernet. All inputs have compressors, equalizer, gate and audio gain functions and are designed for both line and mic level audio signals. Phantom power, sine wave, pink and white noise generators, auto mixer, priority control. Automatically adjust output level according to ambient noise microphone measurements. Limiter and EQ available for all outputs. GPIO programmable inputs and outputs. User friendly and intuitive operation software.



Technical Specifications	OCTO
Power supply	~ 110 V - 230 V / 50 - 60 Hz
Power consumption	44 VA
Input type	Balanced
Phantom power	+ 48 V
Input impedance	2 k Ω
Output impedance	100 Ω
Maximum level	+20 dBu
Maximum gain	-24 dBu
Frequency response	20 Hz – 20 kHz
Distortion	0,005% @ 1 kHz
Connectors	Inputs & outputs – Phoenix connectors, RS-232 – D-SUB 9, RS-485 – Phoenix, Ethernet – RJ-45
Sampling rate	48 k
AD/DA converter	24 bit
Dynamic range	100 dBu
Channel isolation	110 dBu
Weight	4,6 kg.
Dimensions	483 mm x 304 mm x 44 mm

INSTALLATION AMPLIFIERS

iA Installation Amplifiers

The amplifiers for contractors

iA240X, iA360X & iA480X

100 V amplifiers with selectable output power configuration. Fan cooling system, Phoenix output connectors, balanced XLR input and link output connectors (iA240X, iA360X), phoenix input and link connectors (iA480X) with ground lift and 24V DC power supply. These amplifiers are designed for operation under hard conditions and require minimum maintenance after installation. For medium and large public address and voice evacuation systems.



iA240X





iA360X



iA480X

Technical Specifications	iA240X	iA360X	iA480X
Output power	240 W	360 W	480 W
AC power consumption	500 VA	700 VA	850 VA
DC power consumption	390 VA	548 VA	450 VA
Stand by power consumption	30 VA	40 VA	60 VA
Power supply	~ 220 V / 50 Hz or DC 24 V	~ 220V / 50 Hz or DC 24 V	~ 220 V/~110 V 50 Hz/60 Hz or DC 24 V
Outputs	Low impedance outputs - 4 Ω (Phoenix connector), Hi impedance outputs - 100 V, 70 V (Phoenix connector), Link - Balanced XLR		Low impedance outputs - 4 Ω (Phoenix connector), Hi impedance outputs - 100 V, 70 V (Phoenix connector), Link - Phoenix input connector is linked to Phoenix, RCA to RCA connector.
Inputs	Balanced XLR	Balanced XLR	Phoenix, stereo RCA
Frequency response	60 Hz - 20 kHz	60 Hz - 20 kHz	30 Hz - 20 kHz
THD	1 %	1 %	1 %
Signal / noise ratio	90 dB	90 dB	85 dB
Inputs	Sensitivity - 0 dBu, Impedance 10 kΩ		Sensitivity - 0 dBu, Impedance 10 kΩ
Gain Control	-80 dB to 0 dB	-80 dB to 0 dB	-80 dB to 0 dB
High-pass filter	400 Hz	400 Hz	
Cooling	Fan forced air	Fan forced air	Fan forced air
Dimensions	428 mm x 88 mm x 377 mm	428 mm x 88 mm x 377 mm	420 mm x 88 mm x 280 mm
Weight	14,6 kg	19 kg	14,6 kg

INSTALLATION AMPLIFIERS
iA Installation Amplifiers

The amplifiers for contractors.

iA2X250 & iA4X125

Two and four channel amplifiers for 100V, 70V and 4 Ω sound system lines. Switching power supply, input gain control, dual or single input mode, output configuration selector, HP filter, phoenix output connectors. Fan powered cooling system, rack mount. The iA amplifiers are made for operation under hard conditions and require minimum maintenance after installation. These amplifiers are used in a medium and large public address and voice evacuation systems.



Technical Specifications	iA2X250	iA4X125
Output power	2X250 W	4X125 W
AC power consumption	640 VA	660 VA
Power supply	~ 220 V / 50 Hz	~ 220 V / 50 Hz
Stand by power consumption	65 VA	80 VA
Outputs	Selectable output 4 Ω, 70 V or 100 V, Connectors - Screw terminal	
Inputs	Sensitivity - 0 dBu, Impedance 10 kΩ, Connectors - Balanced XLR	
Frequency response	20 Hz - 20 kHz	20 Hz - 20 kHz
THD	0,1 %	0,1 %
Signal / noise ratio	95 dB	95 dB
Controls	Power switch, input gain, input mode, output configuration, HP filter	
Indicators	Signal, protection, output configuration	
Cooling	Fan forced air	
Dimensions	432 mm x 88 mm x 350 mm	432 mm x 88 mm x 425 mm
Weight	7,4 kg	9,7 kg



Every Place
is Unique



Simple. Reliable. Profitable.

AMC® BALTIC Neris kr. 14A, LT-48397, Kaunas, Lithuania / (370 37) 308585 / www.amcpro.eu

MEDIA PLAYER AMPLIFIERS
DMPA Media Player Amplifiers

Media amplifier with integrated music player.

DMPA 60, DMPA 120 & DMPA 240

Class-D amplifier with integrated SD/USB media player is an all-in-one solution for single zone audio installations. Two microphone inputs, phantom power and input priority settings allow easy paging. Internal media player supports SD cards and USB flash drives, or external audio source using AUX input. Internal limiter prevents audio clipping. Amplifier comes in 60 W, 120 W, 240 W and can power both low and high impedance speaker systems. DMPA series devices are ideal choice for small shops, gas stations, waiting rooms, or any other places that need a small, reliable and easy to operate audio system for continuous daily use.

Technical Specifications	DMPA 60	DMPA 120	DMPA 240
Output power	60 W	120 W	240 W
AC power consumption	170 VA	225 VA	400 VA
Power supply	110~240 VAC, 50 Hz/60 Hz		
Outputs	Low impedance output: 4 Ω (Phoenix connector) Hi impedance: 70 V, 100 V (Phoenix connector) Line output (stereo RCA)		
MIC inputs	Sensitivity: -56 dBV Connector: MIC 1 – Phoenix, MIX 2 – XLR / TRS combo Priority: MIC 1 only, switchable Phantom power: MIC 1 only, 24 VDC, switchable		
AUX input	Sensitivity: -6 dBV Connector: stereo RCA		
THD	< 1%		
S/N ratio	MIC 1 & 2, Media player: > 60 dB, LINE: >70 dB		
Frequency response	80 Hz - 18 kHz		
Equalizer	Bass: 100 Hz ±10 dB, Treble: 10 kHz ±10 dB		
Dimensions	44 x 215 x 315 mm		
Weight	1.95 kg	2.60 kg	3.05 kg



DMPA B1 & DMPA B2 rack mounting brackets

DMPA B1 & DMPA B2 – Optional steel brackets for mounting 1 or 2 DMPA series amplifiers in 1U equipment rack space. ▼

Technical Specification	DMPA B1	DMPA B2
Number of DMPA devices	1	2
Height	1 rack unit	
Material	Steel	

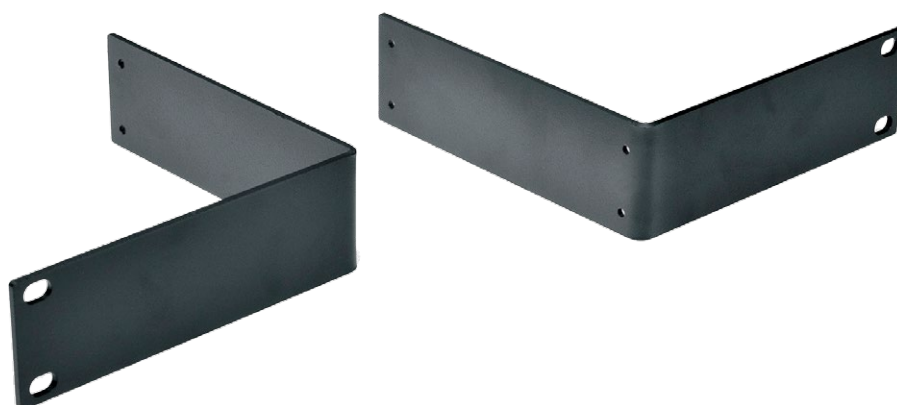

COMMUNICATION AMPLIFIERS

iCOMC Communication Amplifiers

Two channel communication amplifiers with RS232 interface and IR remote control.

iCOMC 2x20

iCOMC 2X20 two channel communication amplifiers with RS232 interface and IR remote control. Designed for small size applications. D class power amplifier, limiter, stereo and bridge mode, tone control, line input, balanced microphone input, phoenix output connector, phantom power and loudness function. Some of functions can be controlled by using IR remote control or RS232. Suitable to be mounted on any flat surface, horizontal or vertical. External power supply



Optional accessory - IR remote control

Technical Specifications	iCOMC 2x20
Output power	2 x 20 W
Power supply	24 V DC 1,5 A
Outputs	Low impedance output - 4 Ω (screw terminal block)
Inputs	Mic: Sensitivity -60 dBu Connector - Balanced Phoenix Line 1 : Sensitivity -7 dBu Connector - 3,5 mm stereo Jack Line 2 : Sensitivity -7 dBu Connector - Stereo RCA
Frequency response	35 Hz - 20 kHz
THD	< 0,03 %
Signal / noise ratio	> 100 dB
Tone control	Bass ± 7 dBu , Treble ± 7 dBu
Controls	Mic and Line input level controls, balance control, tone control, input selector, loudness, limiter and phantom power. RS 232 and IR remote controls.
Indicators	Power, volume, balance, tone
Dimensions	145 mm x 120 mm x 45 mm
Weight	0,6 kg

MIXING AMPLIFIERS
MA Mixing Amplifiers

Compact size mixing amplifiers for music and speech.

MA 30X

30W power, low and high impedance outputs, AUX/Phono and microphone inputs, tone control. Priority input, activated by closing contacts on rear panel. Perfect for use in small size applications such as shops, bars or restaurants, and there's no need for professional installation assistance.



Technical Specifications	MA 30X
Output power	30 W
AC power consumption	57 VA
Power supply	~230 V/ 50Hz
Outputs	Low impedance output – 4 Ω, 8 Ω, 16 Ω (Screw terminal connectors) Hi impedance outputs – 100 V (Screw terminal connectors)
Inputs	Microphones: sensitivity - 55 dB, impedance 10 kΩ, connectors - unbalanced 6.3 mm TRS Jack AUX: sensitivity - 20 dB, impedance 10 kΩ, connectors - Stereo RCA PHONO: sensitivity - 55 dB, impedance 10 kΩ, connectors - Stereo RCA
Frequency response	50 Hz - 20 kHz
THD	Less than 1 % at 1 kHz rated power
Signal / noise ratio	>55 dB
Tone control	Bass ±10 dB, Middle ±10 dB, Treble ±10 dB
Controls	Input level control, tone control, master
Indicators	Power
Dimensions	320 mm × 190 mm × 75 mm
Weight	5 kg
Colour	Black (RAL 9017)

MIXING AMPLIFIERS

MA Mixing Amplifiers

Universal mixing amplifiers for music and voice.

MA60, MA120 & MA240

Universal mixing amplifiers for public address, background music and paging systems.

Audio signal mixing, with a wide choice of input sources with selectable outputs.

Can be used as component of voice evacuation or public address system in the remote rooms, equipped with 24V DC power supply, line and microphone inputs, phantom power supply.



MA60



MA120





MA240

Technical Specifications	MA60	MA120	MA240
Output power	60 W	120 W	240 W
AC power consumption	160 VA	360 VA	600 VA
DC power consumption	90 VA	175 VA	310 VA
Stand by power consumption	20 VA	25 VA	30 VA
Power supply	~ 230 V / 50 Hz or 24V DC		
Outputs	Low impedance output - 4 Ω (Phoenix connector), Hi impedance outputs - 100 V, 70 V, 25 V (Phoenix connector)		
Inputs	Microphone: Sensitivity - 63 dBu, Impedance 10 kΩ, Connectors - Combi XLR Line: Sensitivity - 0 dBu, Impedance 10 kΩ, Connectors - Combi XLR AUX: Sensitivity - Selectable 18 dBu, 12 dBu, 8 dBu, Impedance 10 kΩ, Connectors - Stereo RCA:		Microphone: Sensitivity - 50 dBu, Impedance 10 kΩ, Connectors - Combi XLR Line: Sensitivity - 8 dBu, Impedance 10 kΩ, Connectors - Combi XLR AUX: Sensitivity - 4 dBu, Impedance 10 kΩ, Connectors - Stereo RCA:
Frequency response	50 Hz - 15 kHz	50 Hz - 15 kHz	80 Hz - 16 kHz
THD	< 2 %	< 2 %	1 %
Signal / noise ratio	> 70 dB	> 70 dB	80 dB
Tone control	Bass ± 10 dB, Treble ± 10 dB	Bass ± 10 dB, Treble ± 10 dB	Bass ± 10 dB, Treble ± 10 dB
Controls	Input level, input gain / phantom power selector, tone control, master volume		
Indicators	Power, output level		
Dimensions	420 mm x 88 mm x 280 mm	420 mm x 88 mm x 280 mm	420 mm x 88 mm x 330 mm
Weight	9,3 kg	10 kg	12,8 kg
Accessories	19" Rack mount bracket		
Colour	Black (RAL 9017)	Black (RAL 9017)	Black (RAL 9017)



MASTERS IN PUBLIC ADDRESS

MA21 | Amplifier

This power mixing amp is top in it's class for dual independent zone sound reinforcement. Ideal for bars, restaurants, offices, hotels and educational environments.

Simple. Reliable. Profitable.

www.amcpro.eu

MIXING AMPLIFIERS

MA Multichannel Mixing Amplifiers

Multichannel mixing amplifiers for background music.

MA 21

MA 21 - two zone mixing amplifier for background music and paging applications. Each zone has separate line input selector for music source, tone and volume control. Amplifier is equipped with 3 mic inputs, subwoofer and record line outputs, each zone LED signal level indication. MA 21 amplifier is perfect for two zone applications, but can be used in stereo mode as well.



Technical Specifications	MA 21
Output power	2 x 100 W
AC power consumption	500 VA
Power supply	~230 V/115 V 50/60 Hz
Outputs	Low impedance output - 8 Ω (Binding post connectors) Hi impedance outputs - 100 V (Screw terminal connectors) Record out - 0 dB (RCA connector) Subwoofer out - 0 dB (RCA connector)
Inputs	Microphones: sensitivity -57 dB, impedance 600 Ω, connectors - Balanced XLR (input MIC 1 - priority input) Line x 3: sensitivity -10 dB, impedance 20 kΩ, connectors - Unbalanced RCA
Frequency response	20 Hz - 20 kHz
THD	Less than 0,05% at 1 kHz rated power
Signal / noise ratio	-70 dB
Tone control	Bass ±10 dB, Treble ±10 dB
Controls	Input level control, source selector, tone control, master
Indicators	Power, stereo VU-meter
Dimensions	425 mm x 305 mm x 88 mm
Weight	9 kg
Accessories	19" rack mounting bracket
Colour	Black (RAL 9017)
Phantom power voltage	+13 V

MIXING AMPLIFIERS
MMA Mixing Amplifiers

5 zone mixing amplifiers with interchangeable module and paging station.

MMA 120X & 240X

MMA 120X & 240X five zone D-class mixing amplifiers for commercial and industrial applications. 120W and 240W rated output power. Can be used with optional music source module and five zone paging microphone Page station 5X. Five zone speaker lines, low impedance speaker output, variety of microphone and line inputs make these units universal for any kind of installation. Single slot for interchangeable music source modules, 6 Mic/Line inputs, gain control, paging microphone input, chime function, phantom power, priority inputs, graphic equalizer, five-zone selector. Ideal choice where wide selection of audio line inputs is needed and multi-zone broadcasting is a priority.



Technical Specifications	MMA 120X	MMA 240X
Output power	120W	240W
Power supply	~ 230V / 50 Hz	
Outputs	Low impedance output – 4 Ω (Phoenix connector) Hi impedance outputs – 100V (Phoenix connector)	
Inputs	Microphone: Sensitivity – 50 dBu, connectors – balanced XLR, 6.3 mm TRS Jack Line: Sensitivity – 30 dBu, connector – stereo RCA Remote mic: Sensitivity – 40 dBu, connector – Phoenix Link in: Sensitivity – 17 dBu, connector – 6.3 mm TS Jack Amp in: Sensitivity – 0 dBu, connector – 6,3 mm TS Jack Remote paging: Connector – RJ45	
Phantom power	15V (max.)	
Frequency response	80 Hz - 15 kHz	
Equalizer	125 Hz, 250 Hz, 500 Hz, 1 kHz, 2 kHz, 4 kHz, 8 kHz, ±12 dB	
THD	0,5%	
S/N ratio	75 dB	
Dimensions	420 mm x 320 mm x 88 mm	
Weight	9,76 kg	10,5 kg

FM/AM/USB/SD module for MMA amplifiers

FM/AM/USB/SD – Optional module for MMA 5 zone amplifier with USB flash and SD card player and FM/AM radio tuner. Supports compressed audio files. Volume control, equalizer, mute, input source selection, repeat and random play modes. 6 radio station presets. Simple plug and play installation. ▼

Technical Specification	FM/AM/USB/SD module
Power supply	DC 12 V
Current consumption	0,5 A
Max audio output	+6dB
Frequency response	20 Hz - 20 kHz
S/N ratio	<70 dB
THD	0,1%
Supported audio formats	Compressed audio



PAGE STATION 5X paging microphone

PAGE STATION 5X – Five zone paging microphone for MMA 120X and MMA 240X mixing amplifiers. Chime, signal and clip indicator, microphone volume control, RJ45 connector, condenser microphone capsule. Lock/unlock switch allows locking any selected zone combination. It helps prevent accidental zone selection and makes announcements to the same zones more user friendly. ◀

Technical Specification	PAGE STATION 5X
Power supply	±15 V
Input sensitivity	- 50 dBu
Frequency response	45 Hz - 15 kHz
S/N ratio	<90 dB
THD	<0,1%
Dimensions	140 mm x 60 mm x 205 mm
Weight	0,9 kg
Colour	Black (RAL 9017)

MEDIA PLAYER AMPLIFIERS

MPA Media Player Amplifiers

Media amplifiers with integrated music player.

MPA 30

MPA 30 - mixing media amplifier with integrated USB and SD MMC card player/recorder and FM radio tuner. Audio signal mixing, low and high impedance outputs, priority input and tone control. Preamp output and preamp input. Recording function is performed on memory cards or USB Flash drive. Selectable gain (AUX/ Phono), stereo RCA input. No need for professional installation assistance, and it's so easy to use. The MPA 30 supports compressed audio files and is an excellent device for small size applications where amplification with music source and audio signal mixing is required.

With external 12V DC power supply capability.



Technical Specifications	MPA 30
Output power	30W
AC power consumption	60VA
Power supply	~230V/50Hz or 12V DC
Outputs	Low impedance output- 4 Ω (Screw terminal connectors) Hi impedance outputs- 25 V,70 V, 100 V (Screw terminal connectors) Preamp Out - output level 0 dBu
Inputs	MIC: Sensitivity- 47 dBu Priority Input - MIC 1 Connectors- Balanced TRS 6.3 jack AUX/PHONO: Sensitivity- 17 dBu (when switch is set to AUX position) Sensitivity- 47 dBu (when switch is set to PHONO position) Connector- RCA AMP input: Sensitivity - 0 dBu Connector- RCA
Frequency response	80 Hz -18 kHz
Tone control	Bass ±12 dB, Treble ±12 dB
THD	< 0,5%
Signal/ noise ratio	>75 dB
Controls	MIC and AUX/PHONO input level controls, tone control, USB SD MMC card player volume control, master volume control
Indicators	Power
Dimensions	280 mm x 190 mm x 75 mm
Weight	4,5 kg

MEDIA PLAYER AMPLIFIERS

MPA Media Player Amplifiers

Media amplifiers with integrated music player.

MPA 60

MPA60 – D class mixing media amplifier powered by switching power supply. Integrated USB, SD card player/recorder, FM radio and Bluetooth player interface with IR remote control. Low and high impedance outputs, priority input, phantom power and tone control. Audio recording function is performed on memory cards or USB Flash drive. For precise input gain settings all rear panel inputs have gain adjusting potentiometers. No cooling FAN inside. User-friendly control, no need for professional installation assistance. The MPA 60 supports compressed audio files and is an excellent device for small size applications where amplification with music source or audio signal mixing is required.



Technical Specifications	MPA 60
Output power	60W
Power supply	110~230V, 50/60Hz
Outputs	Low impedance output - 4Ω, 8Ω Hi impedance outputs 70V, 100V
Inputs	MIC: Sensitivity: -6dB ~ -50dB Priority Input - CH1 Connectors: - XLR for CH1, Balanced TRS 6.3 jack for CH2 and CH3 LINE: Sensitivity: +14 ~ -30dBu Connector: RCA, 3,5mm TRS jack TELE PAGING: Sensitivity: 0 ~ -30dBu Connector: Phoenix
Frequency response	80 Hz -18 kHz
Tone control	Bass 100Hz ±12 dB, Treble 10kHz ±12dB
THD	< 0,5%
Indicators	Power, audio signal, clip, protect.
Controls	MIC and LINE input level controls, tone control, USB SD card player volume control, master volume control.
Phantom power	14V
Dimensions	260 mm x 27 mm x 90 mm
Weight	3,5 kg

MIXING PREAMPLIFIER

iMIX5 Zone Router

Stereo mixing preamplifier for background music and voice.

iMIX5

Zone router with 5 stereo outputs for multi-zone audio control. iMix5 has 4 audio source inputs, which can be routed to any of 5 available outputs. Sources at individual zones can be selected by zone selector on front panel, using wall plate controller or RS232 commands. iMix5 has internal media player with USB, Bluetooth, FM receiver and AUX input. Priority input and external mute connectors for emergency audio installations.

Page station MIC iMIX is designed for zone paging.



Technical Specifications	iMIX 5
Inputs	Line inputs: 3 x stereo phoenix, sensitivity -12.5 dBV Mic input: 1 x XLR, sensitivity -41 dBV Call station input: 1 x RJ45, sensitivity +4 dBV
Outputs	5 x stereo phoenix, rated 600 ohm 1 x XLR for zone monitoring
EMG input: SN ratio to microphone input SN ratio to line input	Sensitivity -10 dBV 65 dB 73 dB
Media player	USB / Bluetooth / FM radio / AUX input
Phantom power	+24V DC
Frequency response	±3 dB 20 Hz - 20 kHz
THD +N	<0.1% @ 1kHz
Controller inputs	RS232 interface 5 x RJ45 connectors for wall plate controllers
Power supply	100-240 Vac, 50/60 Hz
Dimensions	483 x 177 x 44 mm
Weight	1.76 kg

MIC iMIX

MIC iMIX – five zone paging microphone with intuitive control buttons for iMIX 5. Pressing selected zone button or all zone button enables to make announcements to selected zone or all zones together. It is possible to start announcement immediately or with a chime. Chime options can be selected with DIP switches. Local audio source can be connected using TRS jack input. ▶

Technical Specification	MIC iMIX
Microphone type	Condenser microphone
Polar pattern	Cardioid
Frequency response	-3dB 150Hz - 22kHz
Control	6 x illuminated zone select buttons (1-5, all zones) 1 x Talk button
Input impedance	Mic: 600 Ohms, Aux: 50k Ohms
Output impedance	Balanced 600 Ohms
Input level Mic	-46dBV, Aux: -10dBV
Output level	10dBV
S/N ratio	-60dB
Connectors	RJ45, 24VDC power jack, 3.5mm stereo TRS, XLR
Interface	RS-485
Max. connection length	500m
Power supply	24Vdc, 500mA
Dimensions	460 mm x 140 mm x 115mm
Weight	670 g



WC iMIX

WC iMIX – glass look, touch sensitive surface for zone audio source selection, volume control and mute. Wall controller has built-in audio input to connect extra audio source locally. iMIX5 support up to 5 WC iMIX controllers, one unit per zone. Available in black and white. ◀

Technical Specification	WC iMIX
Max. connection length	500m
Connector type	RJ45
Mounting depth	38mm
Power supply	24VDC
Dimensions	86 mm x 86 mm x 38 mm
Weight	128g



MIXING PREAMPLIFIERS

iMIX 2 Multi-Zone Mixing Preamplifiers

Stereo two-zone mixing preamplifier.

iMIX 2

A stereo two-zone mixer preamplifier with digital source selector, volume, tone and balance controls. iMix 2 mixer preamplifier has all the main features necessary for audio installations: input gain control, phantom power on/off, input priority, tone, balance control and RS232 interface for remote control of main functions. With iMIX2 mixer preamplifier it is possible to create 2 stereo zone or 2 mono zone audio systems, with paging possibilities.



Technical Specifications	iMIX 2
Power supply	~ 230 V / 50 Hz
AC power consumption	20 VA
Frequency response	10 Hz - 50 kHz
THD	< 0,01 %
Input impedance	RCA - 20 kΩ (unbalanced) Phoenix - 47 kΩ (balanced)
Input gain	Line -10 dB Mic -50 dB
Output	Zone - 1 maximum output level + 15dB, impedance - 10 kΩ Zone - 2 maximum output level + 15dB, impedance - 10 kΩ
Priority inputs	Input 4
Tone control	Bass ±12 dB, Treble ±12 dB
HUM & Noise	-87 dB
Crosstalk	- 50 dB @ 1 kHz
Dimensions	44 mm × 482 mm × 200 mm, 1U 19" Rack Mount
Weight	4 kg
Colour	Black (RAL 9017)

MIXING PREAMPLIFIERS

iMIX Stereo Preamplifiers

Mixing preamplifiers for background music and voice.

iMIX 63

Mixing preamplifier for background music and public address. Six balanced COMBO XLR inputs with 6 selectable MIC/LINE inputs and 3 stereo RCA inputs. Phantom power is on the board and activated by external dip switch on each universal COMBO XLR input. Priority on the first universal input. For emergency operation, an external 24V DC power source can be used.



Technical Specifications	iMIX 63
Power supply	~ 230 V / 50 Hz or DC 24V
DC power consumption	9,6 VA
AC power consumption	10,5 VA
Phantom power voltage	20 V (max.)
Input impedance	Microphone input 1,4 kΩ Line input 10 kΩ
Output impedance	120 Ω
Input gain	Combo XLR input (Mic level) - 52 dBu Combo XLR input (Live level) - 12 dBu RCA input - 4 dBu
Maximum input level	Balanced XLR input (Mic level) - 15 dBu Balanced XLR input (Live level) + 12 dBu
Maximum output level	Master output + 16 dBu / Mono output + 27 dBu Monitor output + 27 dBu / Rec output + 21 dBu
Frequency response	20 Hz - 22 kHz
THD	0,03 % @ 1 kHz
Signal / Noise ratio	> 103 dBu
Crosstalk (input to output)	- 82 dBu
Priority inputs	Input 1
Tone control	Low ± 10 dB @ 80 Hz, Mid ± 10 dB @ 2,5 kHz, High ± 10 dB @ 12 kHz"
Dimensions	44 mm × 483 mm × 195 mm, 1U 19" Rack Mount
Weight	2,9 kg
Colour	Black (RAL 9017)





SELECT THE MUSIC OF YOUR CHOICE

MP 22 | 2 zone music player
2 zone music player with paging.
Each player combines FM radio,
Bluetooth, SD and USB.
Zone volume and EQ control.

Simple. Reliable. Profitable.

www.amcpro.eu

MUSIC PLAYERS

MP Music Players

Rack mount music players.

MP 22

Two-zone audio player with two independent players with separate FM and Bluetooth audio receivers. Plays audio files from SD cards and USB drives. Individual volume and tone controls, selectable input for each output. Two-zone paging is available with AMC TALK ST Z2, providing gain and tone control, phantom power and signal priority. External audio sources can be connected using 2 stereo line inputs or 3,5mm TRS AUX input on the front panel.



Technical Specifications	MP 22
Power consumption	10 VA
Power supply	115 V or 230 V, 50/60 Hz
Outputs	Main: output level – 6 dBu, connector – balanced Euro block Link: output level – 0 dBu, connector – stereo RCA
Inputs	Line: sensitivity – 0 dBu, impedance – 4,7 kΩ, connector – stereo RCA Microphone: sensitivity – 56 dBu, impedance – 600 Ω, connector – 5pin XLR AUX: sensitivity – 0 dBu, impedance 4,7 kΩ, connector 3,5 mm TRS jack
Phantom power	+48 V
Media player	Radio station memory: 30 stations Max. USB flash size: 32 GB
Antennas	FM antenna: monopole F-type connector, Bluetooth antenna: internal, working distance > 10 m
Frequency response	20 Hz – 20 kHz
THD	0.10 %
Tone control	Bass: 100 Hz ±12 dB Treble: 10 kHz ±12 dB
Remote control	IR remote
Dimensions	483 mm × 103 mm × 44 mm
Weight	1.7 kg

MUSIC PLAYERS
DAB RADIO player

DAB and FM radio player.

DAB RADIO

DAB RADIO - rack mount professional music player with built-in DAB and FM tuners. These professional player can be used 24 hours a day 7 days a week. Radio tuner has 20 radio presets, RDS. IR remote control is included in delivery with each player.



Technical Specifications	DAB RADIO
Power supply	~230V/50Hz
Power consumption	50 VA
Output connector	Stereo RCA
FM frequency range	87,5 MHz - 108 MHz
DAB frequency range	174,928 MHz - 239,1 MHz
Radio station presets	20
Audio output level	-6 dBu
THD	0,3 %
Antenna	75 Ω
Dimensions	482 mm x 44 mm x 185 mm
Weight	3,4 kg
Material	Steel
Colour	Black

MUSIC PLAYERS
Live Radio Player

Internet RADIO and FM radio player.

LIVE RADIO

LIVE RADIO – a modern music player with integrated Internet radio player, Media player, FM radio tuner and USB flash reader. Device is connected to LAN network over Wi-Fi or cable interface. Main functions can be controlled with IR remote control. RDS and ID3 support.

This device is engineered to provide online music setups, with surprising capabilities.



Technical Specifications	LIVE RADIO
Power supply	~ 230V/ 50 Hz
Max power consumption	20W
Music sources	Internet radio FM radio Media player USB flash
Inputs	75Ω unbalanced FM antenna terminal 2.4 GHz SMA terminal for Wi-Fi antenna RJ45 (Ethernet) cable terminal
Outputs	Stereo RCA Optical output TOSLINK
Max output level	+2 dBu
FM frequency range	87.5 – 108 MHz
FM preset stations	10
Internet radio preset stations	10
Media player	Supports compressed audio formats



MUSIC PLAYERS
MP Music Players

Rack mount music players.

MP01 & MP02

Rack mount music players with CD, FM tuner, SD card and USB players inside. These players are designed to be used all day, every day, true 24/7. They are carefully assembled utilising the highest quality components and will work as hard as you can push them. With 10 radio station presets, RDS and CD text support and IR Remote control included. The MP01, 02 and 03 all have different output configurations so can be tailored for specific applications.



Technical Specifications	Tuner section
Tuning frequency range	87,5 Hz – 108 MHz
IF frequency	10,7 MHz
30 dB quieting sensitivity	10 μ V
Signal / Noise ratio	60 dB
IF rejection	75 dB
Image rejection	25 dB
THD	0,8 %
Stereo separation	30 dB @ 1 kHz
Frequency response	100 Hz – 10 kHz

Technical Specifications	MP 01
FM synthesizer tuner	
60 preset memories	
CD with mechanic & electronic anti-shock, CD, CD-R, CD-R/W, USB and SD card reader, Compressed audio files support	
Input:	FM 75 Ohm unbalanced antenna terminals USB/SD port for flash disc
Output:	XLR audio output for FM L and R channels XLR audio output for CD/USB/SD L and R channels
Power supply	~230V /50Hz
Power consumption	50 VA
Weight	3,5 kg
Dimensions	482 mm \times 44 mm \times 250 mm



Technical Specifications	CD section
Output level	1,2V \pm 2 dB
Output level difference between L R channels	less than 2 dB
Frequency response (using 1 kHz reference)	20 Hz – 20 kHz
Seperation	60 dB @ 1 kHz
THD	0,1 % @ 1 kHz
Signal / Noise ratio	70 dB



Technical Specifications		MP 02
FM synthesizer tuner		
10 preset memories		
CD with mechanic & electronic anti-shock, CD, CD-R, CD-R/W, USB/SD, Compressed audio files support		
Input: FM 75 Ohm unbalanced antenna terminals USB and SD port for flash disc		
Output: Stereo RCA audio output for FM and CD L and R channels		
Power supply	~230V / 50Hz	
Power consumption	50 VA	
Weight	3,5 kg	
Dimensions	482 mm × 44 mm × 250 mm	



Technical Specifications		CD section
Output level		1,2 V ± 2 dB
Output level difference between L R channels		less than 2 dB
Frequency response (using 1 kHz reference)		20 Hz – 20 kHz
Seperation		60 dB @ 1 kHz
THD		0,1 % @ 1 kHz
Signal / Noise ratio		70 dB

* Both MP01 & MP02 include remote control

Technical Specifications		Tuner section
Tuning frequency range		87,5 Hz – 108 MHz
IF frequency		10,7 MHz
30 dB quieting sensitivity		10 µV
Signal to noise ratio		60 dB
3 dB limiting		8 µV
IF rejection		75 dB
Image rejection		25 dB
THD		0,8 %
Stereo separation		30 dB @ 1 kHz
Frequency response		100 Hz – 10 kHz



MUSIC PLAYERS

MP Music Players

Rack mount music players.

MP 02B

MP 02B music player with integrated CD player, FM tuner, USB/SD reader and Bluetooth player interface.
Single source selectable for playback: FM tuner, CD player, USB/SD card reader or Bluetooth interface player.

IR remote control for CD player, USB/SD reader and FM radio. RCA stereo output.



Technical Specifications	MP 02B
CD player, FM tuner, USB/SD reader and Bluetooth interface	
CD drive with mechanic & electronic anti-shock, CD, CD-R, CD-R/W, USB/SD, Compressed audio files support.	
Input: FM 75 Ohm unbalanced antenna terminals USB and SD port for flash disc	
Output: Stereo RCA audio output for FM and CD, L and R channels	
Power supply	230 V AC
Power consumption	50 VA
Weight	3,8 kg
Dimensions	482 mm × 44 mm × 250 mm

	CD section
Output level	1,2 V ± 2 dB
Output level difference between L, R channels	less than 2 dB
Frequency response (1 kHz reference)	20 Hz – 20 kHz
Separation	60 dB @ 1 kHz
THD	0,1 % @ 1 kHz
Signal to noise ratio	70 dB

	Tuner section
Tuning frequency range	87,5 Hz – 108 MHz
Preset memory	30 radio stations
Signal to noise ratio	60 dB
THD	0,8 % @ 1 mV 40 kHz dev.
Stereo separation	30 dB @ 1 kHz
Frequency response	100 Hz – 10 kHz

	Bluetooth section
Working distance	5 m
Signal to noise ratio	60 dB
THD	0,2 %
Stereo separation	less than 60 dB
Signal to noise ratio	less than 60 dB



MUSIC PLAYERS
MP Music Players

Rack mount music players.

MP 03

Rack mount music players with CD, FM tuner, SD card and USB players inside. These players are designed to be used all day, every day, true 24/7. They are carefully assembled utilising the highest quality components and will work as hard as you can push them. With 10 radio station presets, RDS and CD text support and IR Remote control included.

The MP01, 02 and 03 all have different output configurations so can be tailored for specific applications.



Technical Specifications	MP 03
FM synthesizer tuner	
60 preset memories	
CD with mechanic & electronic anti-shock, CD, CD-R, CD-R/W, USB/SD, Compressed audio files support	
Input:	FM 75 Ohm unbalanced antenna terminals USB/SD port for memory stick
Output:	Stereo RCA and balanced mono Phoenix outputs for FM Stereo RCA and balanced mono Phoenix outputs for CD/USB/SD
Power supply	~230V/ 50Hz
Power consumption	50 VA
Weight	3,5 kg
Dimensions	482 mm × 44 mm × 250 mm

Technical Specifications	CD section
Output level	1,2V ± 2 dB
Output level difference between L R channels	less than 2 dB
Frequency response (using 1 kHz reference)	20 Hz – 20 kHz
Seperation	60 dB @ 1 kHz
THD	0,1 % @ 1 kHz
Signal / noise ratio	70 dB



Technical Specifications	Tuner section
Tuning frequency range	87,5 Hz – 108 MHz
IF frequency	10,7 MHz
30 dB quieting sensitivity	10 µV
Signal / noise ratio	60 dB
IF rejection	75 dB
Image rejection	25 dB
THD	0,8 %
Stereo separation	30 dB @ 1 kHz
Frequency response	100 Hz – 10 kHz

MUSIC PLAYERS
MP Music Players

Rack mount music players.

MP 05

MP 05 music player/recorder with integrated SD/MMC and USB flash drive readers and CD player. CD, USB flash drive or SD/MMC card selectable for play back. Recording function is performed on memory cards or USB Flash drive. MP 05 can be controlled by IR remote control, RS232 interface or by trigger inputs in remote control connector.



Technical Specifications	MP 05
Music sources	USB flash, SD / MMC card, CD
Input	Stereo RCA and stereo balanced XLR (REC input)
Output	Stereo RCA and stereo balanced XLR
Power supply	AC 230V 50 Hz
Power consumption	50 VA
Output level	+ 3 dBu ± 2 dBu
Max. REC input level	0 dBu
THD	0,1 %
Frequency resporresponse	20 Hz - 20 kHz
Signal to noise ratio	70 dB
Stereo reparation	60 dB
Supported audio formats	Compressed audio
Remote control	IR remote control, RS 232, triger inputs
Weight	3,74 kg
Dimmensions	482 mm x 44 mm x 250 mm

MUSIC PLAYERS
MP Music Players

Rack mount music players.

MP 06S

MP 06S music players with SPEED CONTROL. This function allows to speed up and slow down the music tracks played from files recorded on CD, SD and USB readers. The player has integrated FM tuner with 30 radio station pre-sets. IR remote control is included in a package . Two separate CD, SD, USB and FM tuner RCA line outputs support 2-zone applications. Priority output is activated if music from CD, USB or SD card stops playing. In this case FM tuner automatically starts playing to that output. Player is ready for 24/7 operation. Ideal music source player for fitness and aerobics.



Technical Specifications	MP 06S
FM synthesizer tuner	
30 preset memories	
CD with mechanic & electronic anti-shock, CD, CD-R, CD-RW, USB, SD, Compressed audio files support	
Input:	FM 75 Ω unbalanced antenna terminal USB / SD port for memory stick
Output:	3 x Stereo RCA
Power supply	AC 230 V 50 Hz
Power consumption	50 VA
Weight	19" rack
Dimensions	Black RAL9017

Technical Specifications	CD section
Output level	+ 3 dBu ± 2 dBu
Output level difference between L R channels	less than 2dB
Frequency response	20 Hz - 20 kHz
Separation	60 dB @ 1 kHz
THD	0,1 %
Signal to noise ratio	70 dB

Technical Specifications	Tuner section
Tuning frequency range	87,5 Mhz - 108
Signal to noise ratio	60 dB
Frequency response	20 Hz - 20 kHz
Separation	30 dB
THD	0,8 %
Frequency response	100 Hz - 10 kHz

POWER AMPLIFIERS
A Power Amplifiers

Professional two channel power amplifiers.

A100

Modern design with ultra slim body. Screw terminal speaker connectors and balanced Phoenix input connectors with a fan cooling system and bridge mode selector. Can be used for live music, background music and voice. These professional power amplifiers are designed in order to meet the increasing demand of low power amplifiers for the installation market. These stereo power amplifiers have complete circuit fault protection and offer a superior performance.



Technical Specifications	A 100
Output power	Rated 100 W + 100 W (4 Ω), 70 W + 70 W (8 Ω)
Power supply	~230 V/115 V 50/60Hz
Outputs	Screw terminal block
Inputs	Connectors - Balanced Phoenix, Impedance - 10 kΩ, input sensitivity - 0,775V
Frequency response	25 Hz - 25 kHz
THD	< 0,03 %
Signal / noise ratio	> 100 dB
Damping factor	> 400 at 8 Ω
Controls	Power switch, volume, mode selector
Indicators	Power, signal, clip, protect
Dimensions	482 mm x 45 mm x 320 mm
Weight	7,8 kg
Mounting	19" rack
Colour	Black (RAL 9017)

POWER AMPLIFIERS
A Power Amplifiers

Professional two channel power amplifiers.

A200

Modern design with ultra slim body. Screw terminal speaker connectors and balanced Phoenix input connectors with a fan cooling system and bridge mode selector. Can be used for live music, background music and voice. These professional power amplifiers are designed in order to meet the increasing demand of low power amplifiers for the installation market. These stereo power amplifiers have complete circuit fault protection and offer a superior performance.



Technical Specifications	A 200
Output power	Rated 200 W + 200 W (4 Ω), 130 W+130 W (8 Ω)
Power supply	~230 V/115 V 50/60Hz
Outputs	Screw terminal block
Inputs	Connectors - Balanced Phoenix, Impedance - 10 kΩ, input sensitivity - 0,775V
Frequency response	25 Hz - 25 kHz
THD	< 0,03 %
Signal / noise ratio	> 100 dB
Damping factor	> 400 at 8 Ω
Controls	Power switch, volume, mode selector
Indicators	Power, signal, clip, protect
Dimensions	482 mm x 45 mm x 320 mm
Weight	9 kg
Mounting	19" rack
Colour	Black (RAL 9017)



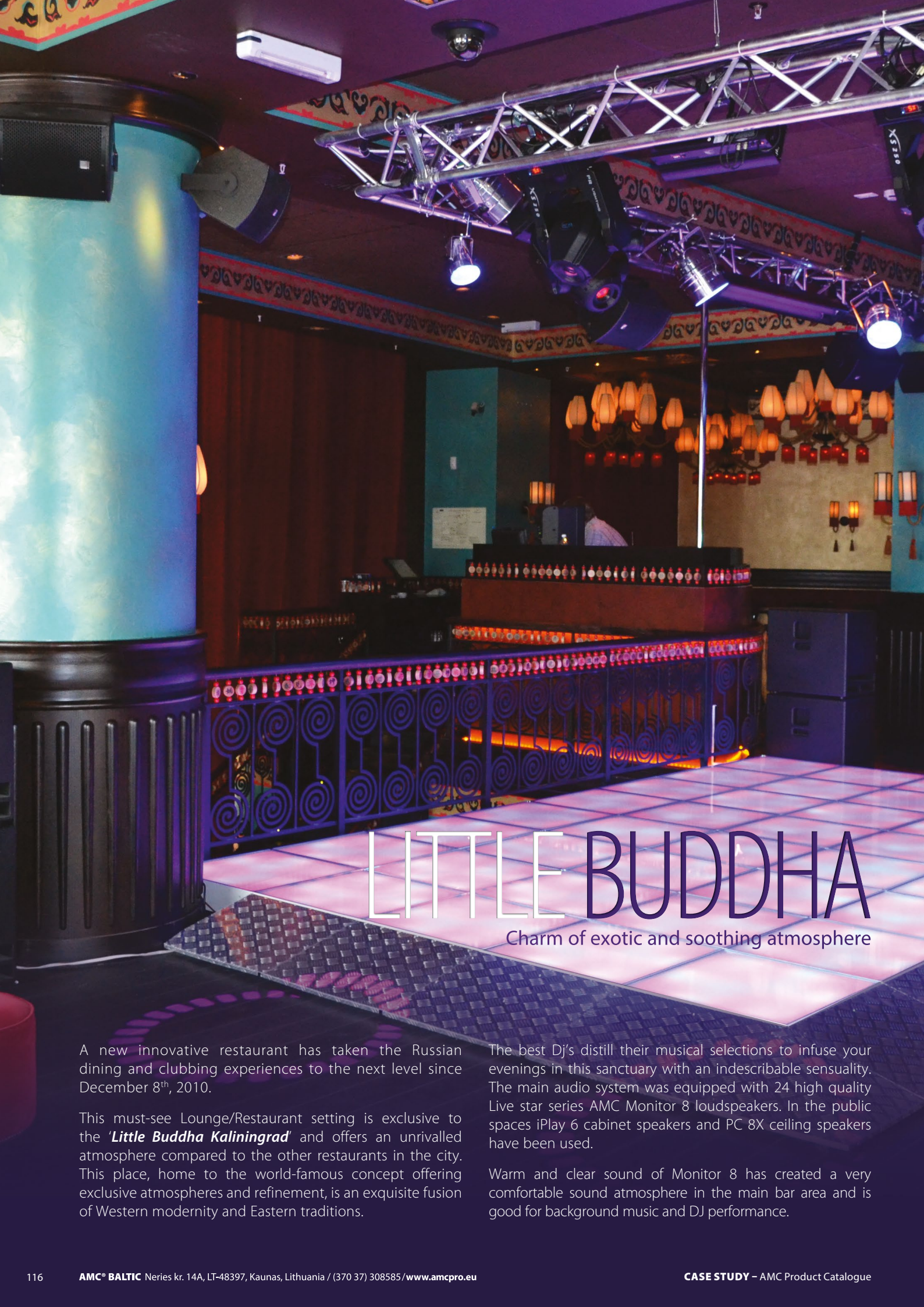

LITTLE BUDDHA

Charm of exotic and soothing atmosphere

A new innovative restaurant has taken the Russian dining and clubbing experiences to the next level since December 8th, 2010.

This must-see Lounge/Restaurant setting is exclusive to the **'Little Buddha Kaliningrad'** and offers an unrivalled atmosphere compared to the other restaurants in the city. This place, home to the world-famous concept offering exclusive atmospheres and refinement, is an exquisite fusion of Western modernity and Eastern traditions.

The best DJ's distill their musical selections to infuse your evenings in this sanctuary with an indescribable sensuality. The main audio system was equipped with 24 high quality Live star series AMC Monitor 8 loudspeakers. In the public spaces iPlay 6 cabinet speakers and PC 8X ceiling speakers have been used.

Warm and clear sound of Monitor 8 has created a very comfortable sound atmosphere in the main bar area and is good for background music and DJ performance.

MICROPHONES INDEX

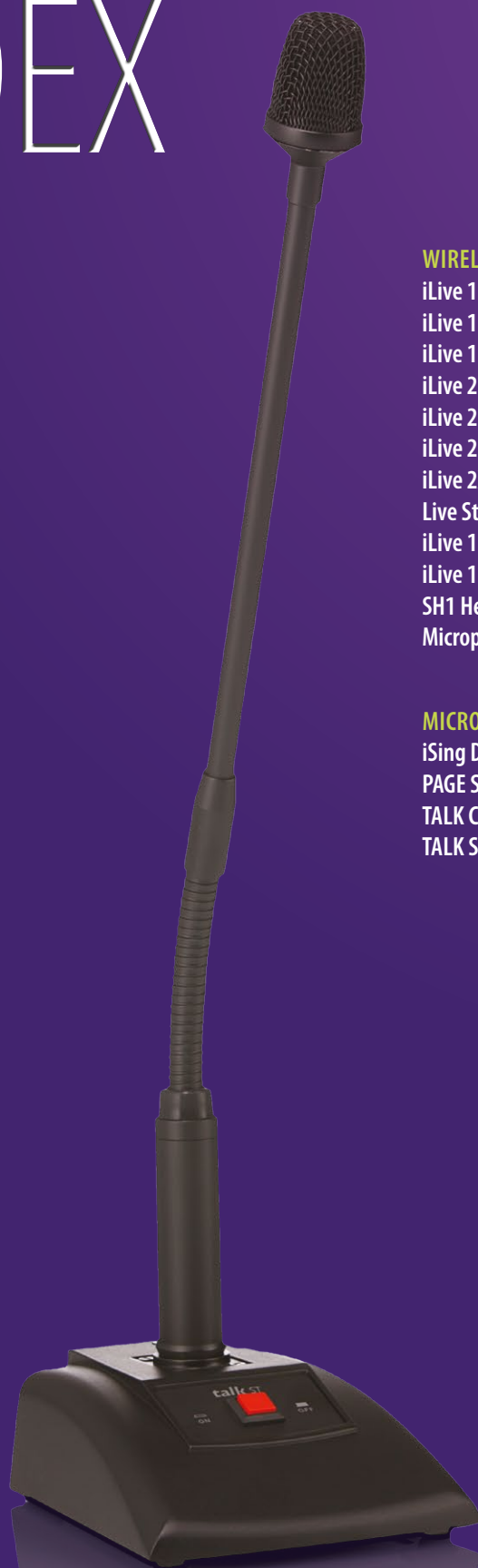

WIRELESS MICROPHONES

iLive 1 Handheld Wireless Microphone System	118
iLive 1 Headset Wireless Microphone System	119
iLive 1 Lavalier Wireless Microphone System	120
iLive 2 Handheld Wireless Microphone System	121
iLive 2 Headset Wireless Microphone System	122
iLive 2 Lavalier Wireless Microphone System	123
iLive 2X2 Dual Channel Wireless Receiver	124
Live Star UX3 Fixed Frequency Wireless Microphone System	125
iLive 12HM Headset Microphone	126
iLive 12LM Lavalier Microphone	127
SH1 Headset Microphone.....	128
Microphone Accessories.....	129

MICROPHONES

iSing D Dynamic Vocal Handheld Microphone	130
PAGE STATION Paging Microphone.....	131
TALK C1 / TALK D Gooseneck Microphones.....	132
TALK ST / TALK ST Z2 Table Stands for Gooseneck Microphones ...	133

WIRELESS MICROPHONES
iLive UHF Wireless Microphone Systems

iLive 1 true diversity wireless microphone systems

iLIVE 1 HANDHELD

iLive 1 handheld true diversity wireless microphone system with 32 selectable channels. Automatic channel synchronization and automatic frequency selection. The microphone signal receiver, handheld microphone transmitter and jack/jack cable are included in every package. Advanced design PCB and excellent quality metal body handheld microphone transmitter equipped with dynamic cardioid microphone capsule makes these sets very universal for use on stage and in the conference rooms.

Technical Specifications	iLIVE 1 handheld transmitter
Carrier frequency range	606 MHz - 621 MHz
Modulation	FM
Channels	32
Audio frequency response	45 Hz - 18 kHz
S/N ratio	> 105 dB
Antenna	Built-in spiral antenna
Transmitter's power	15 mW
Working range	90 m (Note: actual range depends on RF signal absorption, reflection and interference)
Polar pattern	Cardioid
Battery	2 x 1,5 V AA Alkaline battery
Dimensions	240 mm (length)
Weight	302 g
Material	Aluminum



Technical Specifications	iLIVE 1 receiver
Power supply	12-15 V DC, 1.25 A
Output	Balanced XLR, unbalanced 6,3 mm TS JACK
Receiver way	Two frequency conversion super-heterodynes
Intermediate frequency	10,7 MHz
Antenna	BNC
T.H.D	< 0,7 %
Sensitivity	6 dB μ V
Image rejection	36 dB
Max. audio output	0 dB
Dimensions (H x W x D)	45 mm x 210 mm x 206 mm
Weight	1.4 kg
Material	Steel enclosure, aluminum front panel

WIRELESS MICROPHONES

iLive UHF Wireless Microphone Systems

iLive 1 true diversity wireless microphone systems

iLIVE 1 HEADSET

iLive 1 headset true diversity wireless microphone system with 32 selectable channels, automatic channel synchronization and automatic frequency selection. The microphone signal receiver, body pack transmitter with head worn, body color condenser microphone and jack/jack cable are included in every package. This system is designed for use in the theatres, conference rooms and on the stage.



Technical Specifications	iLIVE 1 receiver
Power supply	12-15 V DC, 1.25 A
Output	Balanced XLR, unbalanced 6,3 mm TS JACK
Receiver way	Two frequency conversion super-heterodynes
Intermediate frequency	10,7 MHz
Antenna	BNC
T.H.D	< 0,7 %
Sensitivity	6 dB μ V
Image rejection	36 dB
Max. audio output	0 dB
Dimensions (H x W x D)	45 mm x 210 mm x 206 mm
Weight	1.4 kg
Material	Steel enclosure, aluminum front panel

Technical Specifications	iLIVE 1 body pack transmitter
Carrier frequency range	606 MHz - 621 MHz
Modulation	FM
Channels	32
Audio frequency response	45 Hz - 18 kHz
S/N ratio	> 105 dB
Antenna	1/4 wave antenna
Input connector	4 pin mini XLR connector
Transmitter's power	15 mW
Working range	90 m (Note: actual range depends on RF signal absorption, reflection and interference)
Polar pattern	Cardioid
Battery	2 x 1,5 V AA Alkaline battery
Dimensions (H x W x D)	110 mm x 64 mm x 25 mm
Weight	165 g
Material	Plastic

Technical Specifications	iLIVE 1 HM
Capsule type	Condenser
Impedance	200 Ω
Sensitivity	-47 dB
Frequency	45 Hz - 18 kHz
Connectors	4 pin mini XLR connector
Phantom power voltage	5V DC
Cable length	1 m
Weight	15 g
Colour	Skin (RAL 1014)
Accessories	Windscreen

WIRELESS MICROPHONES

iLive UHF Wireless Microphone Systems

iLive 1 true diversity wireless microphone systems

iLIVE 1 LAVALIER

iLive 1 lavalier true diversity wireless microphone system with 32 selectable channels, automatic channel targeting and synchronization with automatic frequency selection. The microphone signal receiver, body pack transmitter with lavalier microphone and jack/jack cable are included in each set. Very stable signal transmission and reception, choice of selectable channel frequencies allows the use of the microphones in a various environments without any distortion.



Technical Specifications	iLIVE 1 LM
Capsule type	Condenser
Impedance	200 Ω
Sensitivity	-46 dB
Frequency	50 Hz - 18 kHz
Connectors	4 pin mini XLR connector
Phantom power voltage	5 V
Cable length	1 m
Weight	21 g
Colour	Black RAL9017
Accessories	Windscreen

Technical Specifications	iLIVE 1 receiver
Power supply	12-15 V DC, 1.25 A
Output	Balanced XLR, unbalanced 6,3 mm TS JACK
Receiver way	Two frequency conversion super-heterodynes
Intermediate frequency	10,7 MHz
Antenna	BNC
T.H.D	< 0,7 %
Sensitivity	6 dB μV
Image rejection	36 dB
Max. audio output	0 dB
Dimensions (H x W x D)	45 mm x 210 mm x 206 mm
Weight	1.4 kg
Material	Steel enclosure, aluminum front panel

Technical Specifications	iLIVE 1 body pack transmitter
Carrier frequency range	606 MHz - 621 MHz
Modulation	FM
Channels	32
Audio frequency response	45 Hz - 18 kHz
S/N ratio	> 105 dB
Antenna	1/4 wave antenna
Input connector	4 pin mini XLR connector
Transmitter's power	15 mW
Working range	90 m (Note: actual range depends on RF signal absorption, reflection and interference)
Polar pattern	Cardioid
Battery	2 x 1,5 V AA Alkaline battery
Dimensions (H x W x D)	110 mm x 64 mm x 25 mm
Weight	165 g
Material	Plastic

WIRELESS MICROPHONES

iLive UHF Wireless Microphone Systems

iLive 2 antenna diversity wireless microphone systems.

iLIVE 2 HANDHELD

iLive 2 handheld antenna diversity wireless microphone system with 32 selectable channels with automatic channel targeting and synchronization. The microphone signal receiver, handheld microphone transmitter and jack/jack cable are included in each set. Advanced design PCB and excellent quality metal body handheld microphone transmitter equipped with dynamic cardioid microphone capsule makes these sets very universal for use on stage and in the conference rooms.

Technical Specifications	iLIVE 1 handheld transmitter
Carrier frequency range	606 MHz - 621 MHz
Modulation	FM
Channels	32
Audio frequency response	45 Hz - 18 kHz
S/N ratio	> 105 dB
Antenna	Built-in spiral antenna
Transmitter's power	15 mW
Working range	60 m (Note: actual range depends on RF signal absorption, reflection and interference)
Polar pattern	Cardioid
Battery	2 x 1,5V AA Alkaline battery
Dimensions	240 mm (length)
Weight	302 g
Material	Aluminum



Technical Specifications	iLIVE 2 receiver
Power supply	12-15 V DC, 1.25 A
Output	Balanced XLR, unbalanced 6,3 mm TS JACK
Receiver way	Two frequency conversion super-heterodynes
Intermediate frequency	10,7 MHz
Antenna	BNC
T.H.D	< 0,7 %
Sensitivity	6 dB μ V
Image rejection	36 dB
Max. audio output	0 dB
Dimensions (H x W x D)	45 mm x 210 mm x 206 mm
Weight	1.3 kg
Material	Steel enclosure, aluminum front panel

WIRELESS MICROPHONES

iLive UHF Wireless Microphone Systems

iLive 2 antenna diversity wireless microphone systems.

iLIVE 2 HEADSET

iLive 2 headset antenna diversity wireless microphone system with 32 selectable channels with automatic channel targeting and synchronization. The microphone signal receiver, body pack transmitter with head-worn, body color condenser microphone and jack/jack cable are included in each set. The system is used on the stage and in the conference rooms.



Technical Specifications	iLIVE 1 HM
Capsule type	Condenser
Impedance	200 Ω
Sensitivity	-47 dB
Frequency	45 Hz - 18 kHz
Connectors	4 pin mini XLR connector
Phantom power voltage	5 V
Cable length	1 m
Weight	15 g
Colour	Skin (RAL 1014)
Accessories	Windscreen

Technical Specifications	iLIVE 2 receiver
Power supply	12-15 V DC, 1.25 A
Output	Balanced XLR, unbalanced 6,3 mm TS JACK
Receiver way	Two frequency conversion super-heterodynes
Intermediate frequency	10,7 MHz
Antenna	BNC
T.H.D	< 0,7 %
Sensitivity	6 dB μV
Image rejection	36 dB
Max. audio output	0 dB
Dimensions (H x W x D)	45 mm x 210 mm x 206 mm
Weight	1.3 kg
Material	Steel enclosure, aluminum front panel

Technical Specifications	iLIVE 2 body pack transmitter
Carrier frequency range	606 MHz - 621 MHz
Modulation	FM
Channels	32
Audio frequency response	45 Hz - 18 kHz
S/N ratio	> 105 dB
Antenna	1/4 wave antenna
Input connector	4 pin mini XLR connector
Transmitter's power	15 mW
Working range	60 m (Note: actual range depends on RF signal absorption, reflection and interference)
Polar pattern	Cardioid
Battery	2 x 1,5 V AA Alkaline battery
Dimensions (H x W x D)	110 mm x 64 mm x 25 mm
Weight	76 g
Material	Plastic

WIRELESS MICROPHONES

iLive UHF Wireless Microphone Systems

iLive 2 antenna diversity wireless microphone systems.

iLIVE 2 LAVALIER

iLive 2 lavalier antenna diversity wireless microphone system with 32 selectable channels with automatic channel targeting and synchronization. The microphone signal receiver, body pack transmitter with lavalier microphone and jack/jack cable are included in each set. Very stable signal transmission and reception, choice of selectable channel frequencies allows the use of the microphones in a various environments without any distortion.



Technical Specifications	iLIVE 2 receiver
Power supply	12-15 V DC, 1.25 A
Output	Balanced XLR, unbalanced 6,3 mm TS JACK
Receiver way	Two frequency conversion super-heterodynes
Intermediate frequency	10,7 MHz
Antenna	BNC
T.H.D	< 0,7 %
Sensitivity	6 dB μ V
Image rejection	36 dB
Max. audio output	0 dB
Dimensions (H x W x D)	45 mm x 210 mm x 206 mm
Weight	1.3 kg
Material	Steel enclosure, aluminum front panel

Technical Specifications	iLIVE 1 LM
Capsule type	Condenser
Impedance	200 Ω
Sensitivity	-46 dB
Frequency	50 Hz - 18 kHz
Connectors	4 pin mini XLR connector
Phantom power voltage	5V
Cable length	1 m
Weight	21 g
Colour	Black RAL9017
Accessories	Windscreen

Technical Specifications	iLIVE 2 body pack transmitter
Carrier frequency range	606 MHz - 621 MHz
Modulation	FM
Channels	32
Audio frequency response	45 Hz - 18 kHz
S/N ratio	> 105 dB
Antenna	1/4 wave antenna
Input connector	4 pin mini XLR connector
Transmitter's power	15 mW
Working range	60 m (Note: actual range depends on RF signal absorption, reflection and interference)
Polar pattern	Cardioid
Battery	2 x 1,5 V AA Alkaline battery
Dimensions (H x W x D)	110 mm x 64 mm x 25 mm
Weight	76 g
Material	Plastic

WIRELESS MICROPHONES

iLive UHF Wireless Microphone Systems

iLive 2X2 dual channel wireless microphone receivers.

iLIVE 2X2

iLive 2X2 dual channel wireless receiver with 2 handheld transmitters, 32 selectable channels and automatic channel targeting. These universal dual channel receivers can be combined with handheld microphone or body pack transmitter together with lavalier or headset microphone. iLive 2X2 receivers can be used with all AMC iLive2 series hand held transmitters and body packs.



Technical Specifications	iLIVE 2X2
Carrier frequency range	606 MHz - 621 MHz
Power supply	12 - 15 V DC, 1.25 A
Outputs	Balanced XLR, unbalanced 6.3 mm TS jack
Receiver way	Two frequency conversion super heterodynes
Intermediate frequency	10.7 MHz
Antenna connectors	BNC
THD	< 0,7 %
Sensitivity	6 dB μ V
Image rejection	36 dB
Max audio output level	0 dBu
Dimensions	45 mm x 210 mm x 206 mm
Weight	1.4 kg
Material	Steel enclosure, aluminum front panel

WIRELESS MICROPHONE SYSTEM
Live Star UHF Wireless Microphone System

Fixed frequency wireless microphone system.

Live Star UX3

Fixed frequency wireless microphone system with handheld transmitter. UX3 systems are available in 4 fixed frequencies: 626.63 MHz, 630.4 MHz, 863.425 MHz, 864.9 MHz. Simple setup, LED backlight display, RF and AF indicators, volume control, dynamic cardioid capsule, balanced XLR and unbalanced 6.3 mm TS jack outputs. iLive UX3 is perfect budget microphone system for schools or small meeting rooms.

Technical Specifications	UX 3
Carrier frequency range	626.63 MHz & 630.4 MHz, 863.425 MHz & 864.9 MHz
Power supply	12 - 16 V DC, 400 mA
Outputs	Balanced XLR, unbalanced 6.3 mm TS jack
Modulation	FM
Frequency response	40 Hz - 18 kHz
THD	0.5 %
S/N ratio	85 dB
Antenna connector	BNC
Max audio output level	-6 dBu (balanced), -12 dBu (unbalanced)
Transmitter power	10 mW
Working distance	60 m (note: actual range depends of RF signal absorpoin and interference)
Capsule polar pattern	Cardioid
Battery	2 x 1.5 V AA alkaline battery
Material	Plastic
Weight	1.4 kg
Receiver dimensions	42 mm x 200 mm x 150 mm



WIRELESS MICROPHONES

iLive Microphones

Microphones for iLive 1&2 body pack transmitters.

iLIVE 12HM

iLive HM headset microphones are ideally suited for vocal sound and speech application which requires much freedom of movement, such as dancing and sports. Microphone capsule diameter is only 3.0 mm. Light headsets allow using this headset very comfortable. For use only with iLive 1 and iLive 2 body pack.

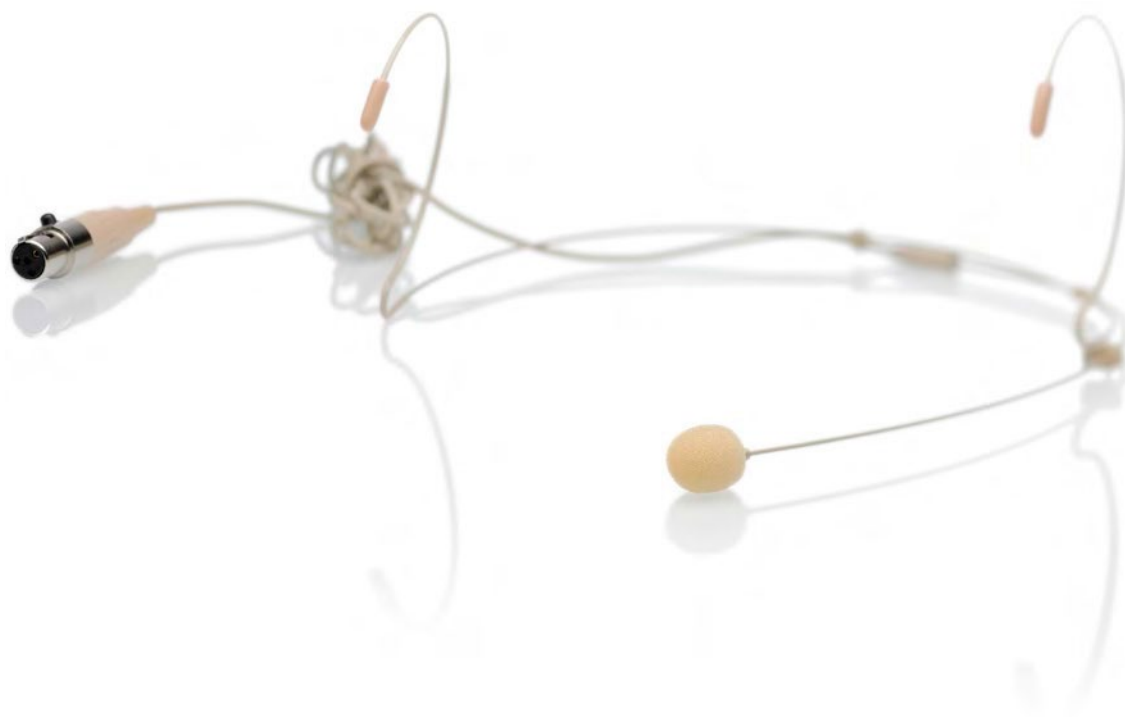

Technical Specifications	iLIVE 12HM
Capsule type	Condenser
Impedance	200 Ω
Sensitivity	-47 dB
Frequency	45 Hz - 18 kHz
Connectors	4 pin - mini XLR
Phantom power voltage	5 V DC
Cable length	1 m
Weight	15 g
Colour	Skin (RAL 1014)
Accessories	Windscreen

WIRELESS MICROPHONES
iLive Microphones

Microphones for iLive 1&2 body pack transmitters.

iLIVE 12LM

iLive 12 LM lavalier microphones are used in TV or radio studio or for conference applications. For use in a wireless mode iLive 1 or iLive2 body pack transmitter is needed.



Technical Specifications	iLIVE 12LM
Capsule type	Condenser
Impedance	200 Ω
Sensitivity	-46 dB
Frequency	50 Hz - 18 kHz
Connectors	4 pin - mini XLR
Phantom power voltage	5 V
Cable length	1 m
Weight	21 g
Colour	Black (RAL 1014)
Accessories	Windscreen

WIRELESS MICROPHONES

Microphones

Microphones for iLive 1&2 body pack transmitters.

SH1

SH1 is light headset for our wireless systems with moisture-repellent and resistant to corrosion condenser capsule. Headset has easily adjustable belt to make the headset size comfortable to wear. The headset is made in skin colour and is virtually invisible during performance. Headset microphone sounds excellent and is sweat proof. Perfect choice for theatre, aerobic, dance show and other live entertainment events.



Technical Specifications	SH1
Capsule type	Condenser
Impedance	1,5 kΩ (at 1 kHz)
Sensitivity	-68 dB
Frequency	70 Hz - 16 kHz
Connectors	4 pin - mini XLR
Operating voltage	1V - 10V
Cable length	1,2 m
Weight	30 g
Colour	Skin (RAL 1014)
Accessories	Windscreen, clip

Mounting accessories for iLive/Mic wireless microphone systems and mini XLR connectors.

MOUNTING BRACKETS

Antenna Front Mount Rack Panel iLive ARP

iLive ARP Antenna rack mount for mounting antennas in the front of the rack. 1U high antenna rack mount panel with antenna cables with BNC connectors.



Product Name	iLive ARP
Cable length	2 x 80 cm
Connectors	BNC
Weight	438 g
Dimensions	45 mm x 485 mm x 2 mm
Colour	Black (RAL 9017)

Receiver Mounting Brackets iLive MB 12

iLive MB 12 rack mount brackets for iLive single channel receivers.



Product Name	iLive MB 12
Set quantity	2 pcs
Material	Steel
Fixing holes	4
Colour	Black (RAL 9017)

Receiver Mounting Brackets iLive MB 12X2

iLive MB 12X2 rack mount brackets for two units of iLive1 and iLive2 receivers.

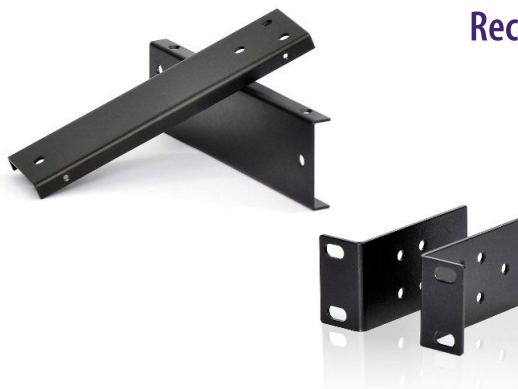

Product Name	iLive MB12x2
Set quantity	4 pcs
Material	Steel
Colour	Black (RAL 9017)

MICROPHONES

Vocal Microphones

Dynamic microphone for stage.

iSING D

Excellent quality metal bodied microphone with dynamic super cardioid capsule. iSing microphone has an integrated on/off switch and XLR connector and comes supplied with a 4.5m XLR-Jack audio cable.



	iSing D
Frequency response	80 Hz – 12 kHz
Sensitivity	-73 dBu
Output impedance	600 Ω
Cable length	4,5 m
Cable connectors	XLR - Mono ¼" jack
Weight	360 g
Switch	ON/OFF

MICROPHONES
Gooseneck Microphones

Gooseneck microphones for paging.

PAGE STATION

Flexible gooseneck condenser microphone with table stand, high sensitivity – 36 dB, 16 mm diameter capsule, 50 – 18 000 Hz frequency response and easily adjustable microphone neck. A phantom power adapter is integrated in to the table stand. Noise free on/off switch with led indicator, rubber coated body, balanced XLR connectors and high quality super cardioid capsule. Supplied with two different size windscreens.



Technical Specifications	Page station
Capsule type	Condenser
Impedance	200 Ω
Sensitivity	-36 dB
Frequency	50 Hz–18 kHz
Connector	3-pin male XLR
Polar pattern	Supercardioid
Phantom power voltage	9 V - 50 V DC
Dimensions	355 mm (microphone length)
Weight	800 g
Material	Table stand - aluminum, goosneck - steel
Colour	Black

MICROPHONES
Goosneck Microphones

Goosneck microphones for paging.

TALK C1 & TALK D

Goosneck microphones can be used with TALK ST and TALK ST Z2 table stands.

TALK C1 – condenser microphone with integrated phantom power adapter, high sensitivity,

80 Hz - 18 kHz frequency response, supplied with windscreen.

Talk D – dynamic microphone with robust construction and steel grill capsule basket.



Table stands sold separately



TALK C1 Capsule



TALK D Capsule

Technical Specifications	Talk C1	TALK D
Capsule type	Electret condenser	Dynamic
Impedance	220 Ω	500 Ω
Sensitivity	-60 dB	-76 dB
Frequency	80 Hz - 18 kHz	150 Hz - 12 kHz
Connector	3-pin male XLR	
Polar pattern	Supercardioid	
Phantom power voltage	9 V - 52 V DC	-
Length	456 mm	425 mm
Weight	120 g	176 g
Material	Steel	
Colour	Black	

MICROPHONES

Table Stands for Goosneck Microphones

TALK table stands for goosneck microphones.

TALK ST & TALK ST Z2

TALK microphones stands for XLR goosneck microphone, with push-to-talk buttons.

TALK ST is for single zone and TALK ST Z2 is for two zone paging. Three buttons on TALK ST Z2 allow to make announcement to zone 1, zone 2 or both zones together.

Technical Specifications	Talk ST	TALK ST Z2
Connector	Microphone input: 3-pin female XLR Cable: 3-pin male XLR	Microphone input: 3-pin female XLR Cable: 5-pin male XLR
Characteristics	Plug-in metal desk stand with push to talk switch for microphones with XLR connector	
Dimensions	45 mm x 110 mm x 140 mm	
Weight	856 g	
Material	Die-cast metal, rubber feet	
Colour	Black	





AMC Baltic Neries Krantinė 14A, LT-48397, Kaunas, Lithuania
T + 370 37 308585 F + 370 37 308583 E info@amcpro.eu

www.amcpro.eu